

SONY

make.believe

Rob McDonough

Senior Applications Engineer

Home Division

Sony Electronics Inc.

What do you get when you surpass the QUALIA 004 in Brightness, quadruple the 90ES in Contrast and 3D performance, and hyper-quadruple the resolution/pixel count?

Full HD
1080



2004

3D
world
Created by Sony



2010

The Incomparable...



VPL-VW1000ES

4K has Come Home!



VPL-VW1000ES

The Worlds 1st **True 4K** resolution
Home Cinema Projector

VPL-VW1000ES



Flagship Features

4096 x 2160 True 4K resolution! Over 8.8 M pixels!
2000 Lumens with 1 Million:1 Dynamic Contrast!
Super-Resolution upscaling to 4K!
4K-upscaled 3D/Anamorphic Ultimate Immersion!
Double the Throw Distance range and Vertical offset!

What is 4K?

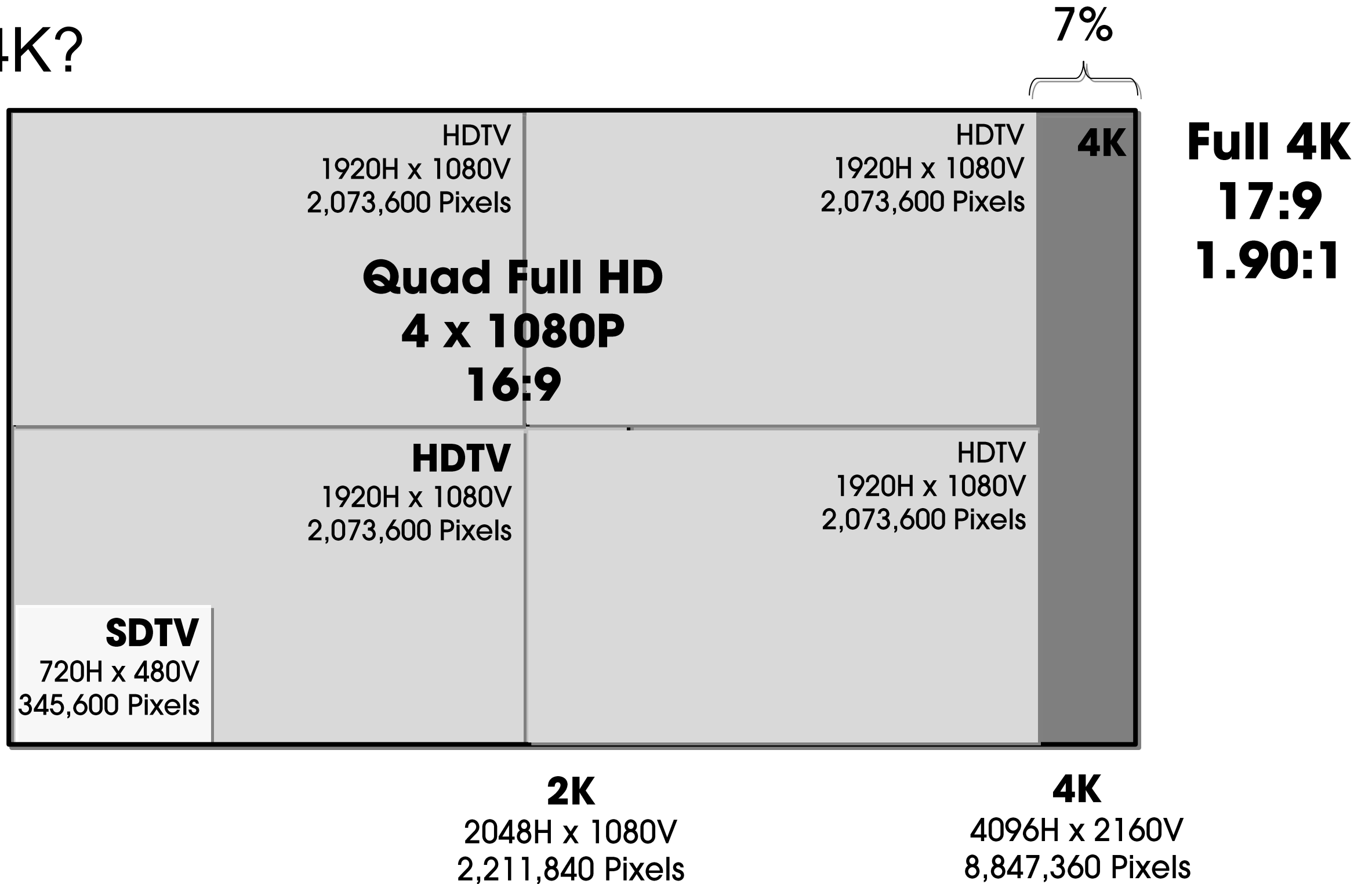

DCI compliant 4096 x 2160 17:9 aspect (1.90:1)

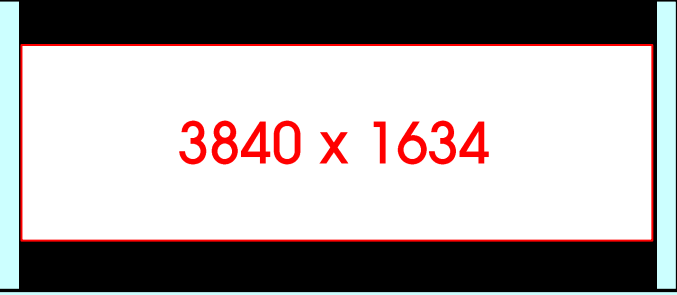
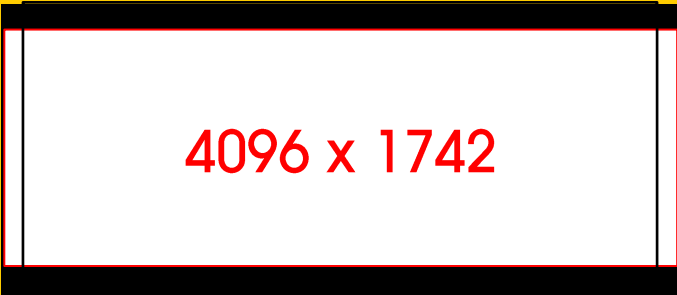
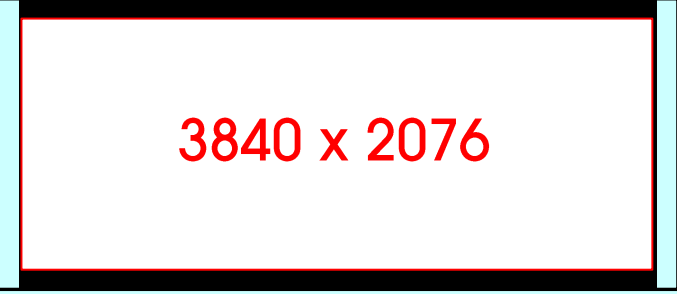
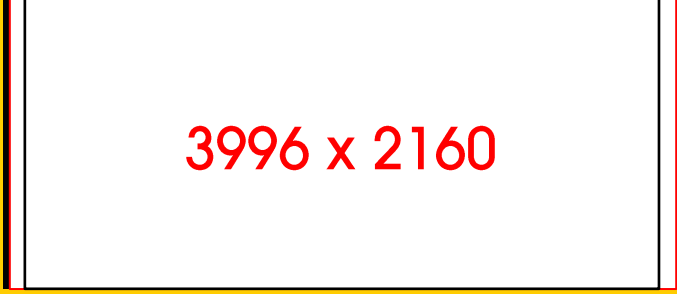
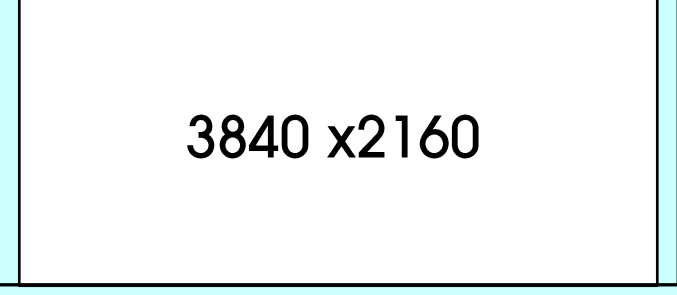
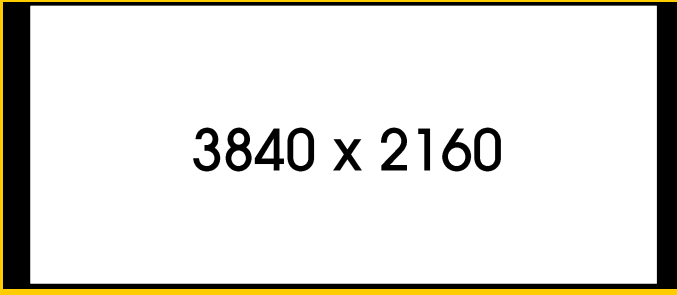
Contents	Input Format	16:9 (3840x2160) 1.78:1	17:9 (4096 x 2160) 1.90:1
Cinema (Wide)	Cinema Scope 2.35 : 1 1920 x 817 or 3840 x 1634	 <p>3840 x 1634</p>	 <p>4096 x 1742</p>
	American Vista 1.85 : 1 1920 x 1038 or 3840 x 2076	 <p>3840 x 2076</p>	 <p>3996 x 2160</p>
HDTV Game	HD 16:9 1.78 : 1 1920 x 1080 or 3840 x 2160	 <p>3840 x 2160</p>	 <p>3840 x 2160</p>

Super-resolution Upscaling

Upscaled from 1080P or Full 4K sources 4K Maximizes Experience Impact & Comfort

Full HD

4K

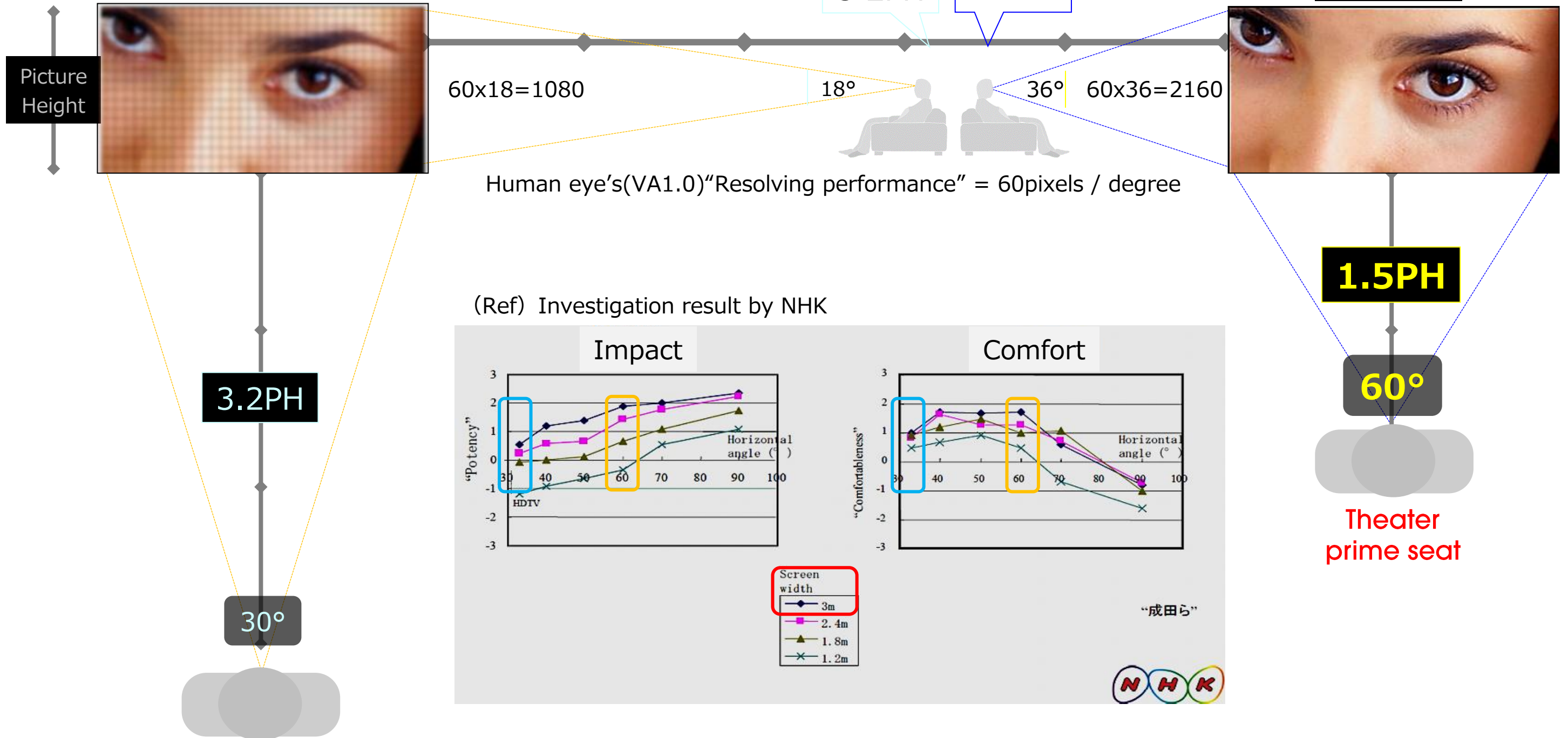

4K – The Ultimate Immersion Advantage

Full HD



If you are too close...

HD 1080P has visible pixels, jagged outlines and screen door effect.

Ideal viewing is 3PH distance

3.0 PH



Now Get up Close and Personal...
Because 4K changes everything!

4K



1.5 Picture Heights



Prime theater seating

The 1000ES creates a whole new level of
Amazing 3D!



2D to 3D Up-Conversion

2D Source

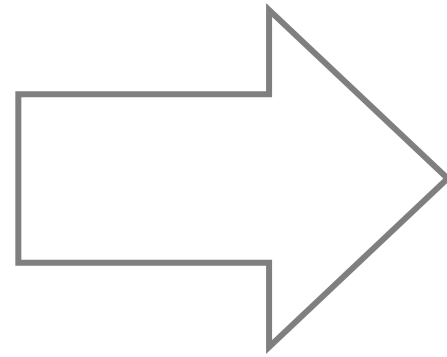

3D Output Viewing

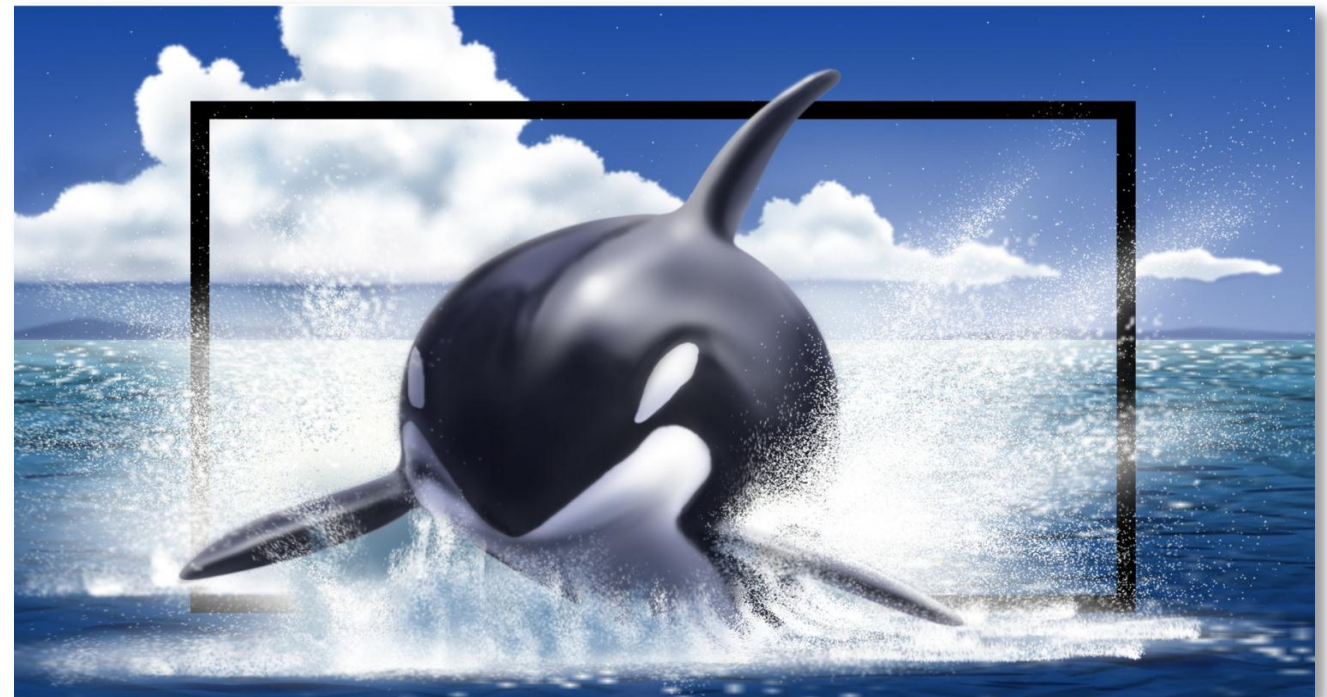

HD Broadcast



Still picture



BD Player

*Simulated 3D only available with HD signal through HDMI connection.

3D Digital driving system: Lower Crosstalk

VW1000 uses new digital panel, driving system different from HW30 and VW95.

VW1000 with Digital Drive

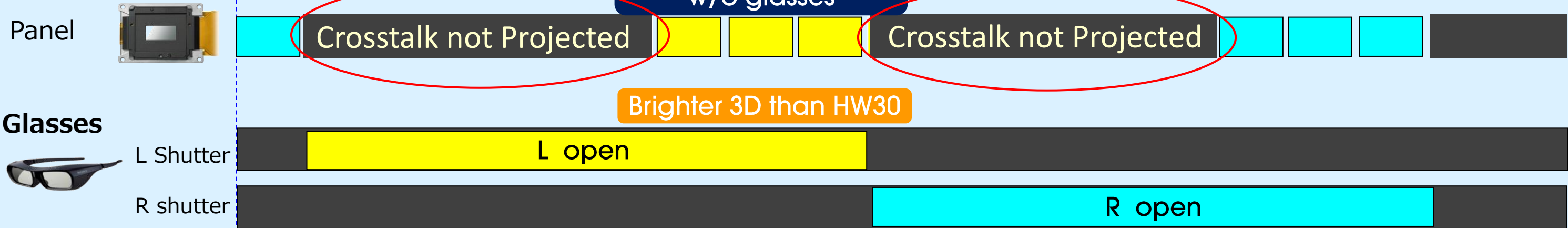

HW30 with Analog Drive

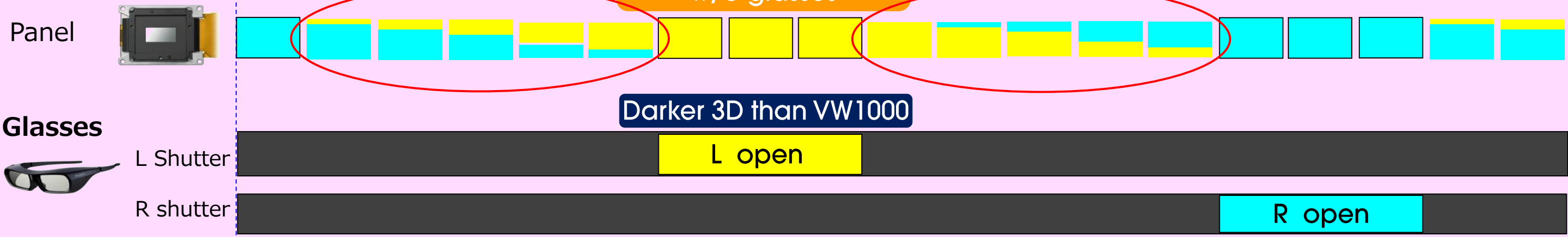

VPLVW1000ES: The Ultimate Immersion Experience

Brighter, more vivid images (up to 2000 lumens)

Larger, more life-sized images (up to 200" screens)

Closer, more intimate viewing (in to 1.5 screen height viewing)

Smaller, more transparent "micro" pixels (down to 1/4 size of 1080P)

Sharper, higher resolution images (up to 8.8 million micro-pixels)

Deeper, near-bottomless blacks (up to 1,000,000:1 Dynamic Contrast)

Clearer, brighter, astonishingly real 3D (enhanced by Digital Panel Drive)

Wider, more eye engaging anamorphic viewing (up to 15' wide)

And, the enveloping synergy of super-resolution upscaled-4K-Anamorphic-3D

World's most Immersive 3D experience

World's 1st 4K up-scaling 3D



Sony's Complete 4K Technology Package

4096x2160
4K Panel

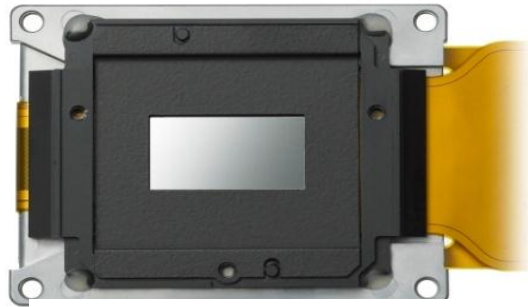

SXR



Super-resolution
Database type
LSI 4K processor



Hi Res 4K
Projection
Lens

4K

Newly developed 4K SXRD panels: 4 micron pitch

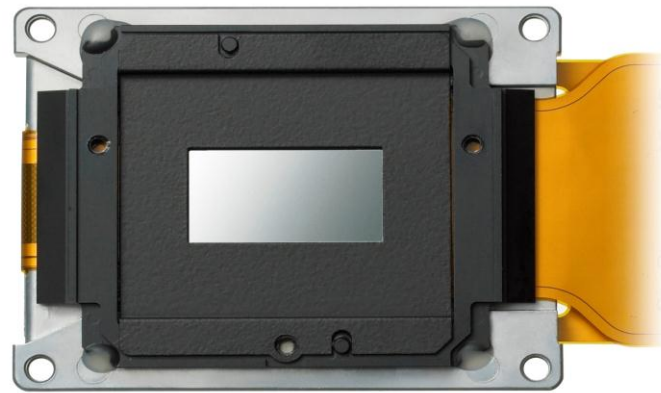

SXRD

4K

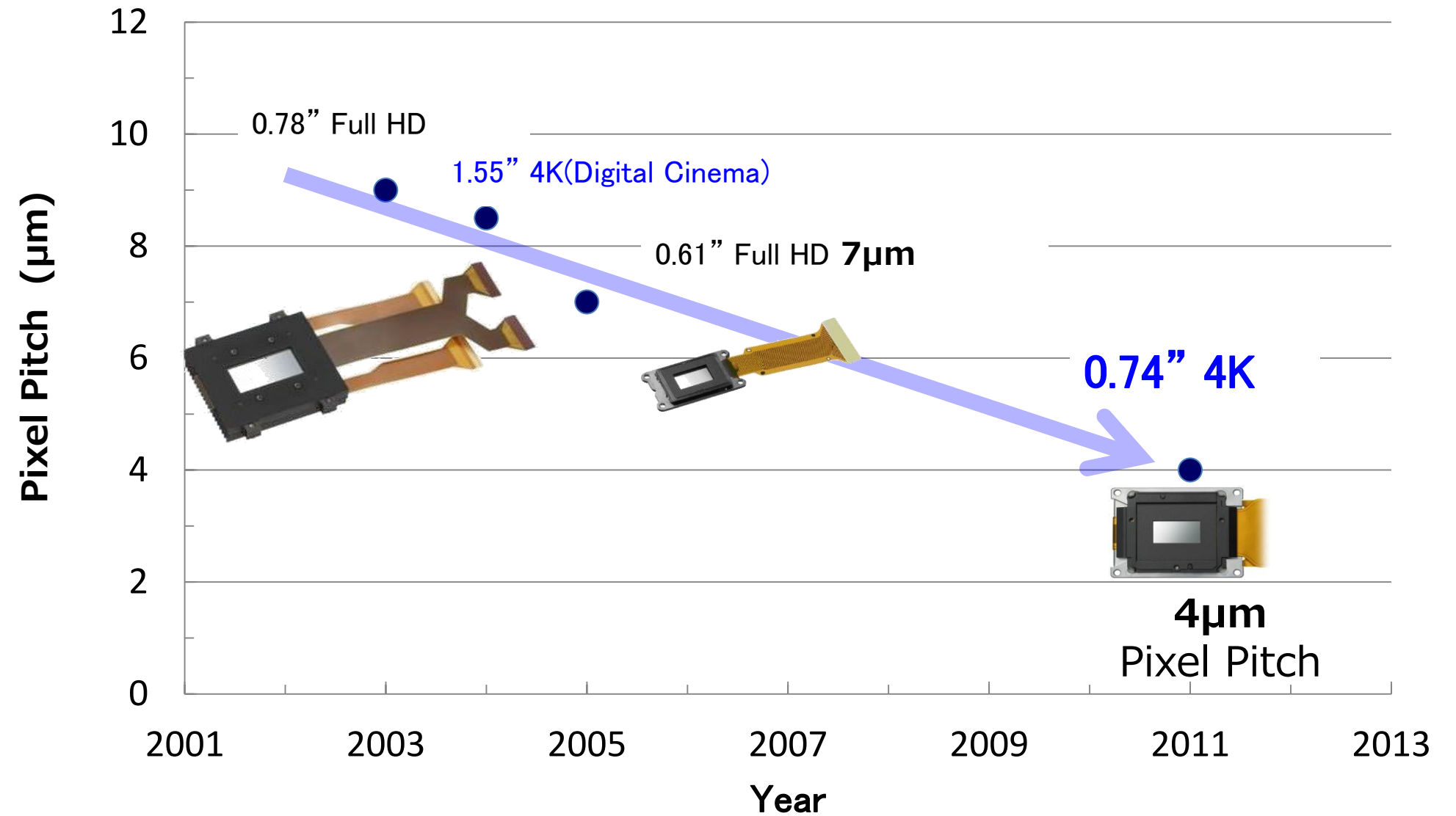

SXRD Flagship Panel with Higher Contrast and Brightness

Current HD Panel

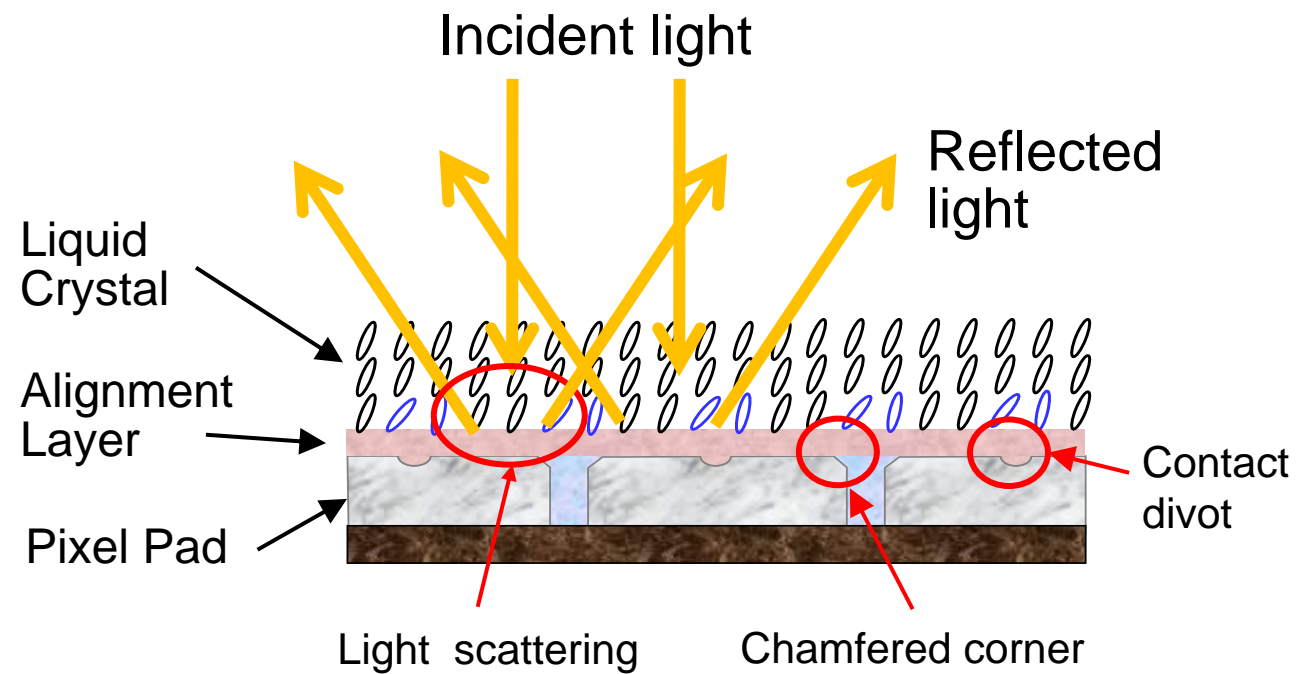

Some rough surface light scattering and liquid crystal molecular misalignment

New 4K Panel

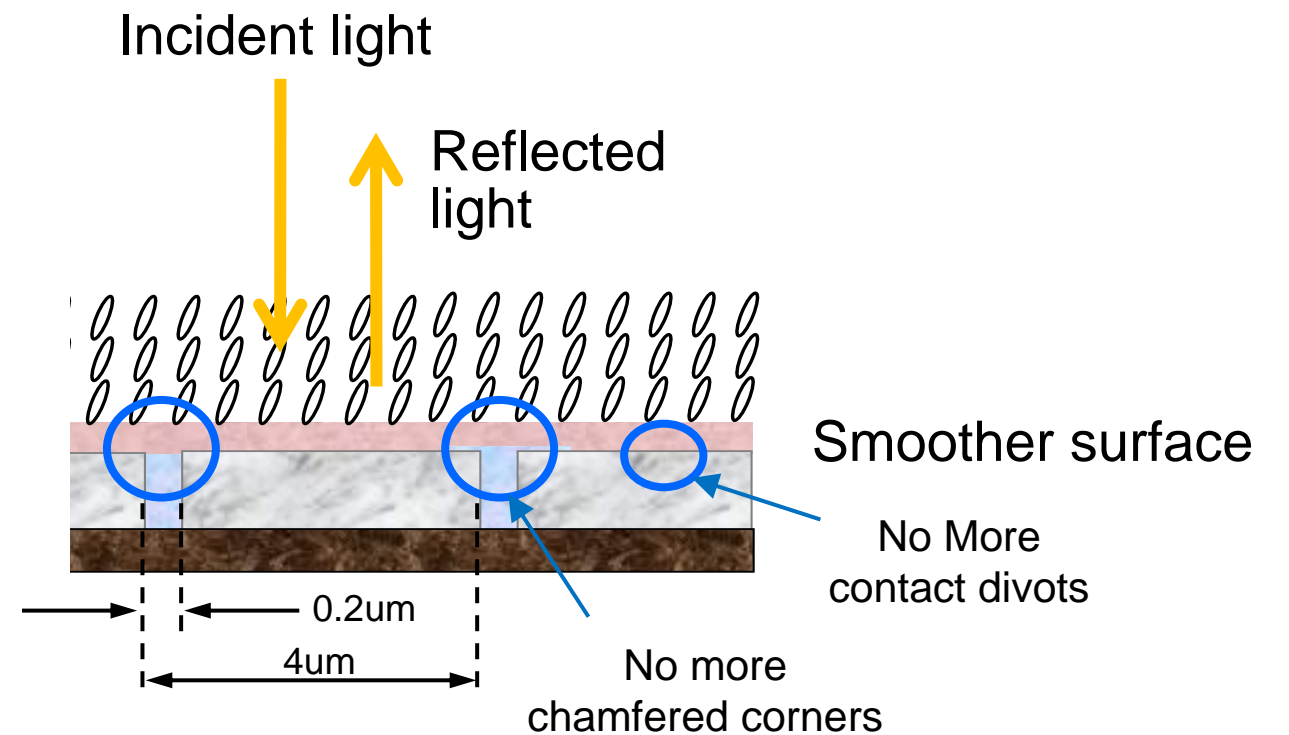

High contrast and high reflectivity, aligned crystals and smooth surface with 4um pixel pitch

Newly developed Database type Super-resolution LSI for new 4K SXRD Panel

Applying a decade of technology advancements refined, optimized, and precisely matched to the newest 4K VW1000ES panel



Convert Full HD images to precise 4K

4K image processed by conventional method



4K image processed by newly developed Super-resolution LSI



4K “Super Resolution” Scaling

2K projector

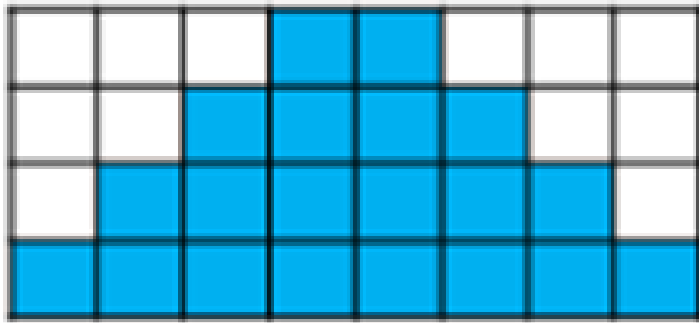

Jaggies and screen door

2K signal on a 4K projector

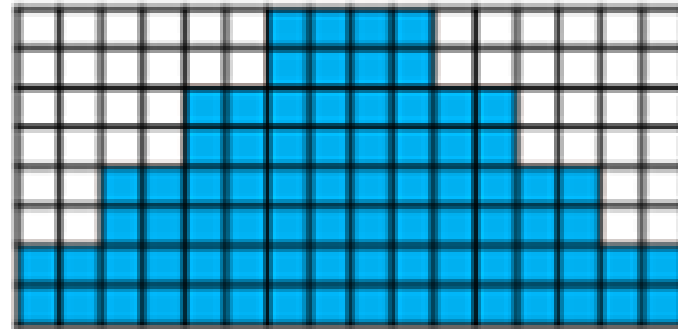

Still has jaggies, but less screen door

2K signal on 1000ES with Sony's “Super resolution” technology

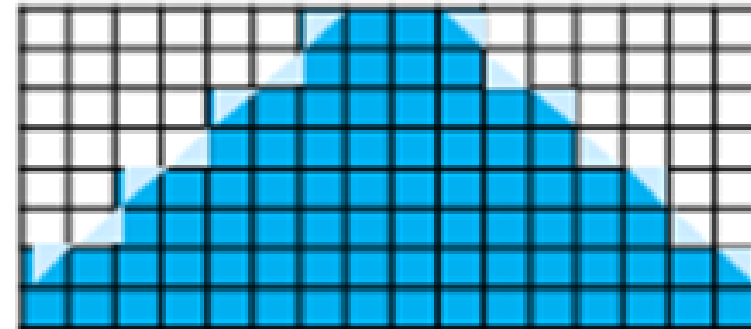

Less jaggies and less screen door

Native 4K Signal

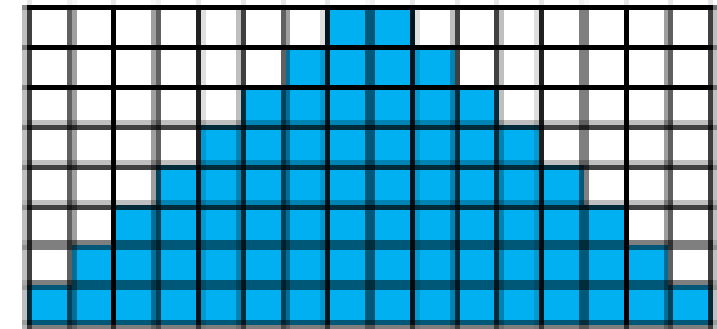

Optimal image

Quality of Image



Newly developed 4K “ARC-F” lens



ARC-F: All Range Crisp-Focus Lens

Structure of 4K “ARC-F” lens

1. Floating Focus method

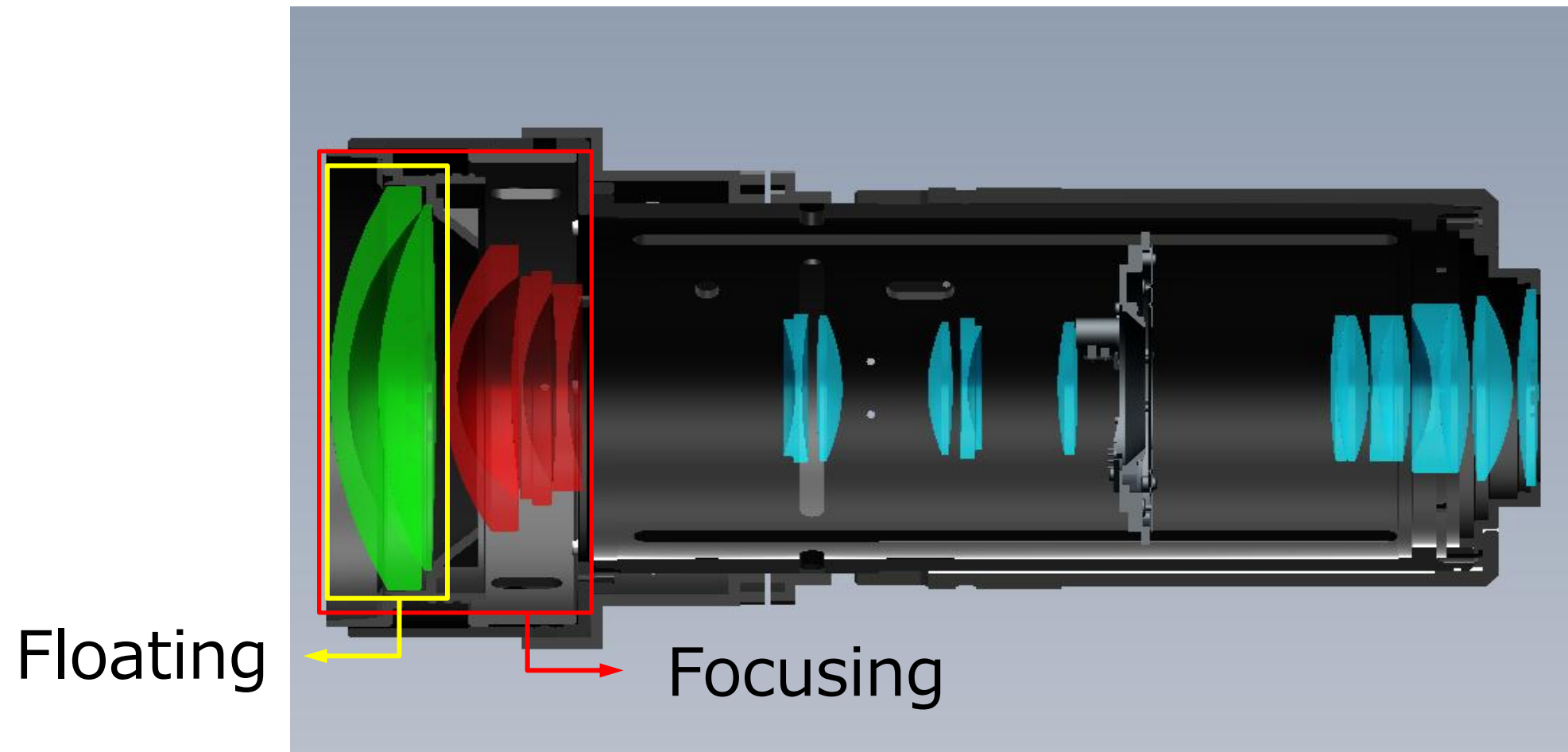

Structure of 4K “ARC-F” lens

2. Extra-low Dispersion glass lens (ED Lens)

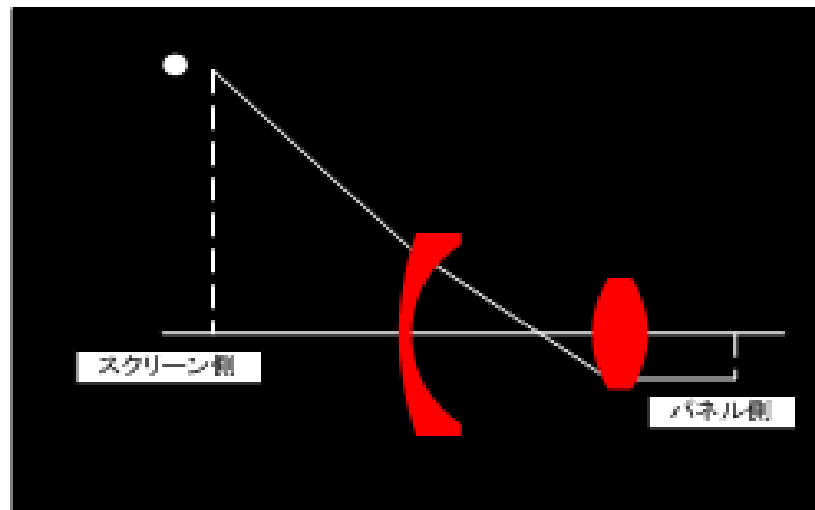
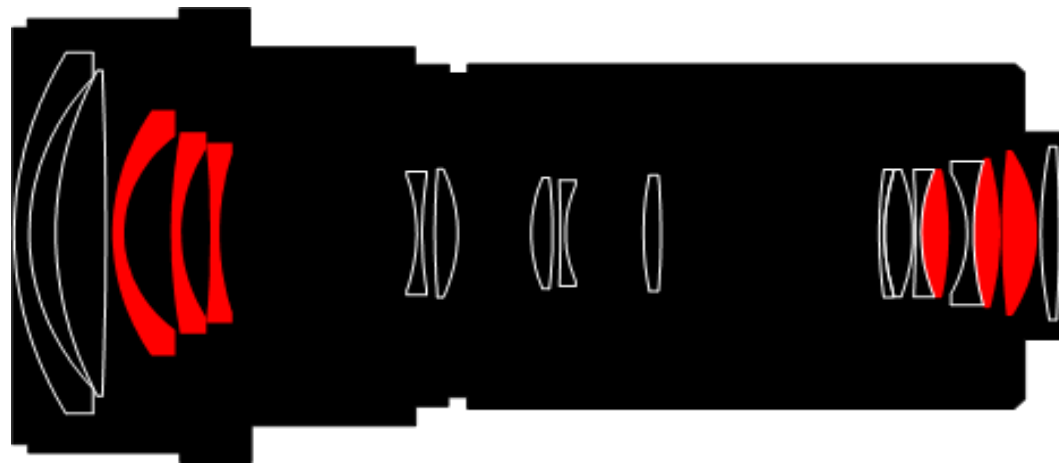

Without ED Lens

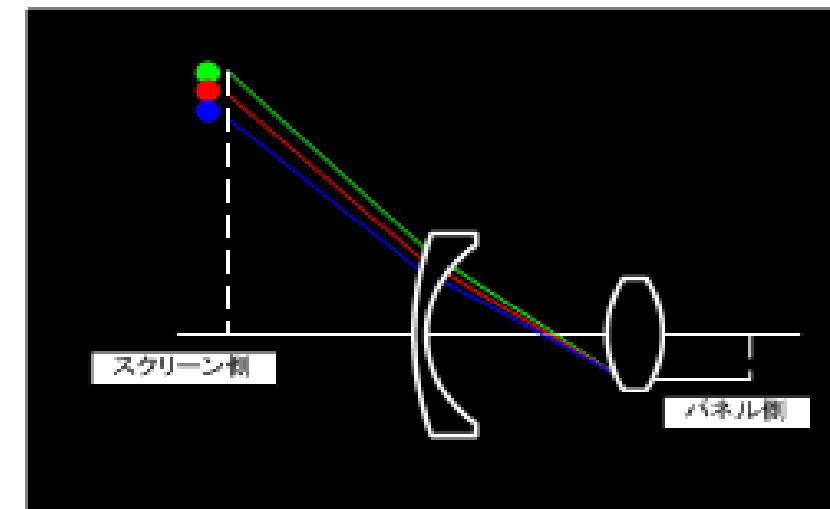

Structure of 4K "ARC-F" lens

3. High resolving performance

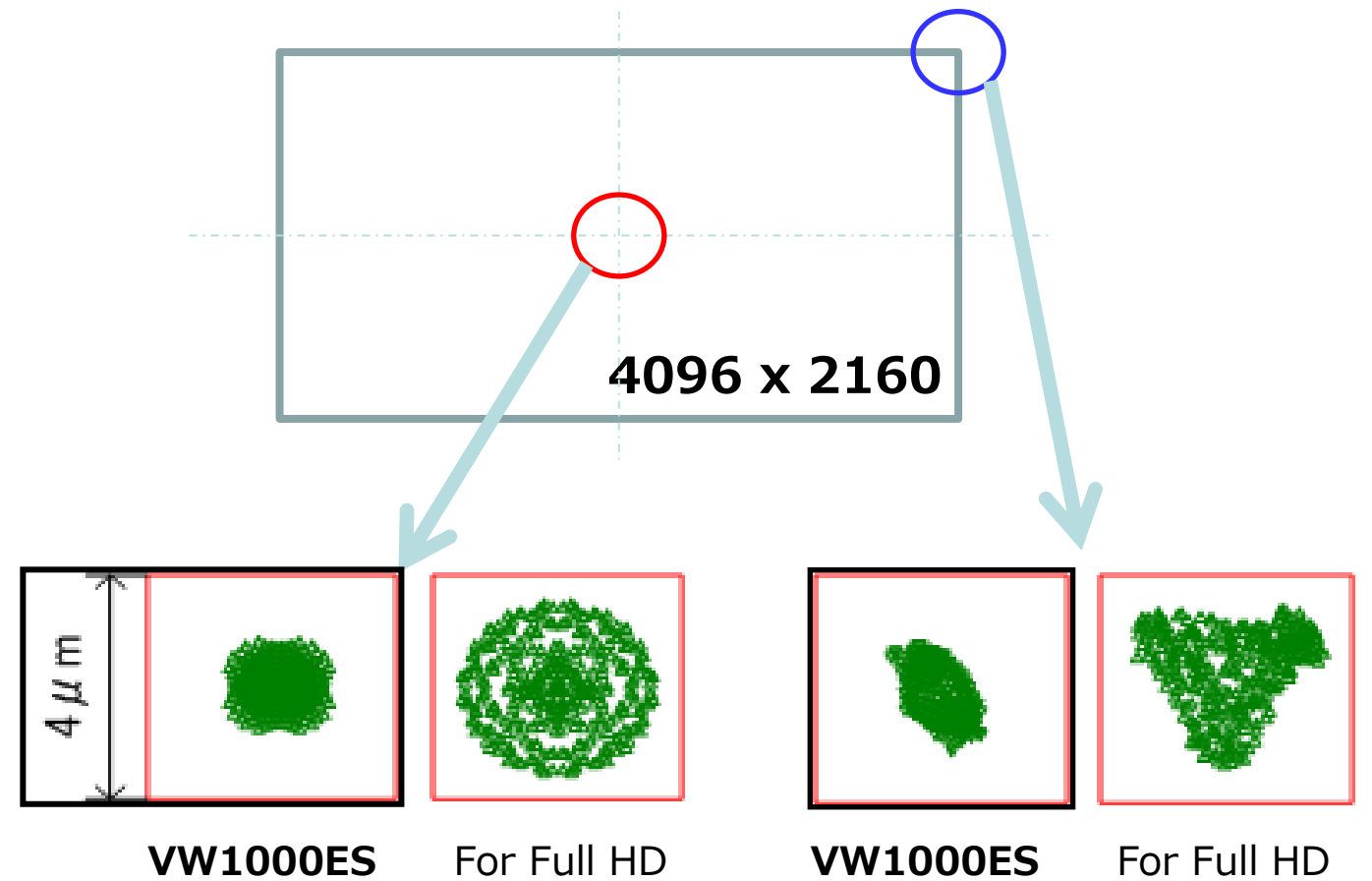
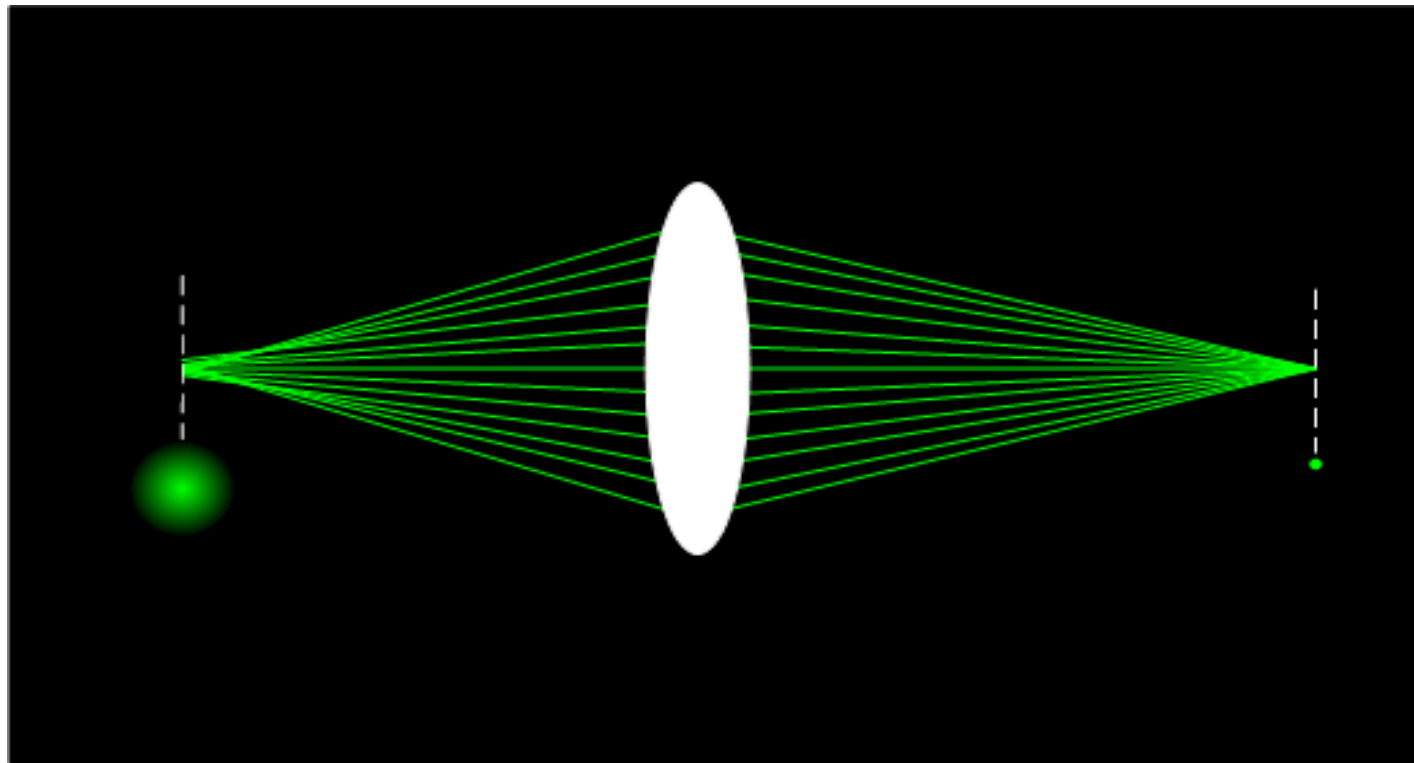

True **4K**

vs.

Imitation 4K

VPL-VW1000ES

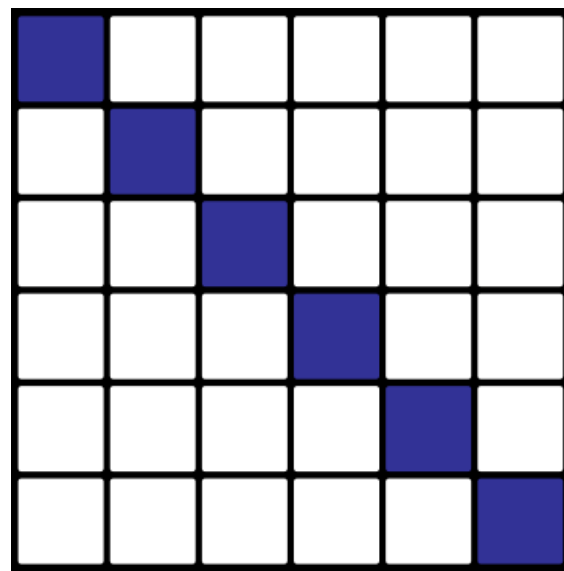

1 Pixel

1/4 size
Micro Pixels

True 4 K Resolution

- Frame Rate **120Hz**
- Detailed and clear thin line
- 4K-3D projection possible

Imitation 4K Technology

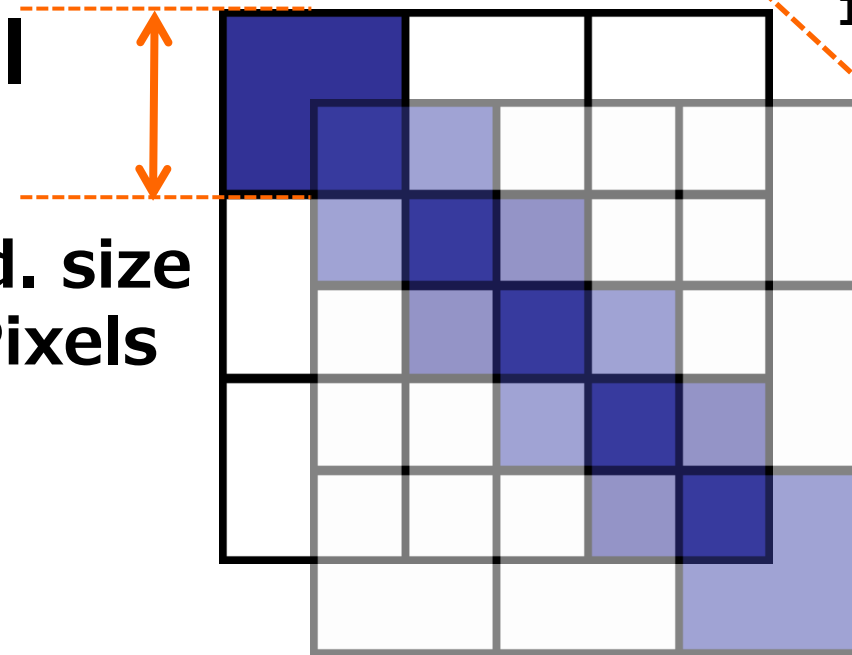

1 Field

2 Field

Time

1 Frame

Imitation 4K Resolution

- Frame Rate **60Hz**
- Thick fuzzy line
- 4K-3D projection NOT possible

Only the VPL-VW1000ES offers 4K upscaled-3D-Anamorphic Projection Capability!

Customers expecting to pay much more than
\$25K for this level of Flagship Performance
may easily decide to take the high road,

The Flagship Top-of-the-Line Method:

With an external Anamorphic Lens System.

Fine Panel Alignment Function

Sony exclusive **1/10th Pixel** increments
Red and Blue Pixel Shift ± 20 steps of 0.1 pixel

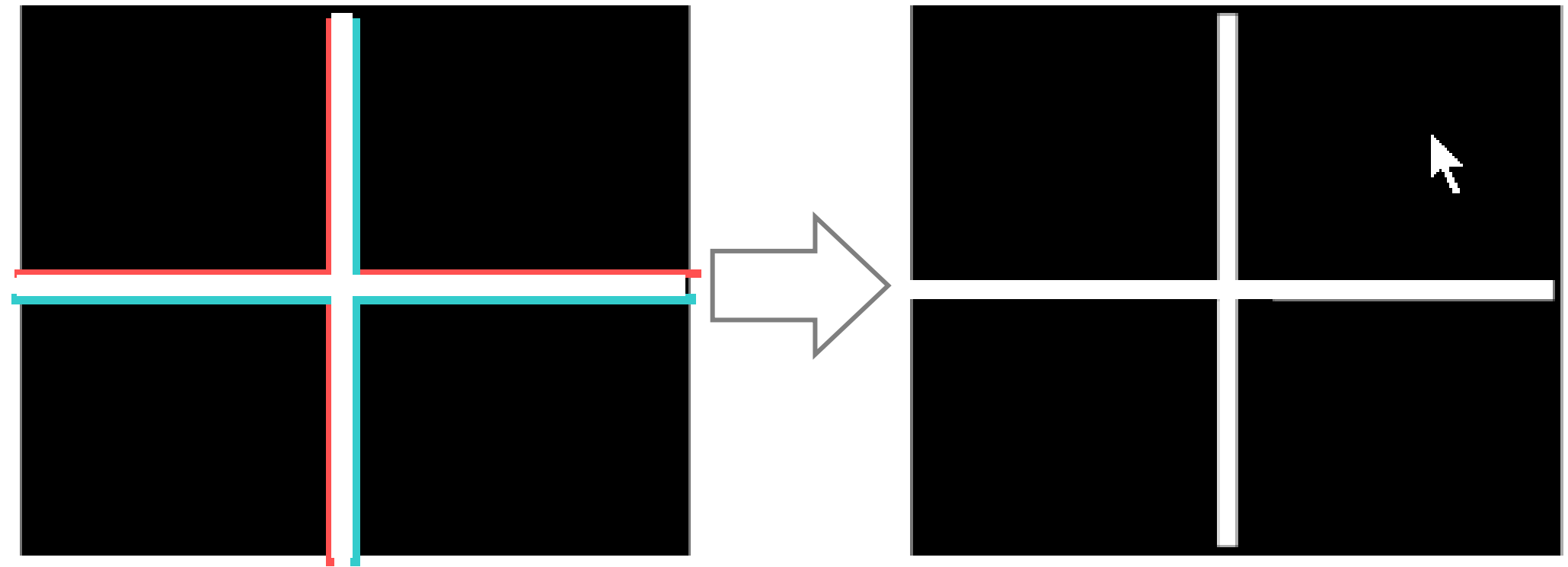
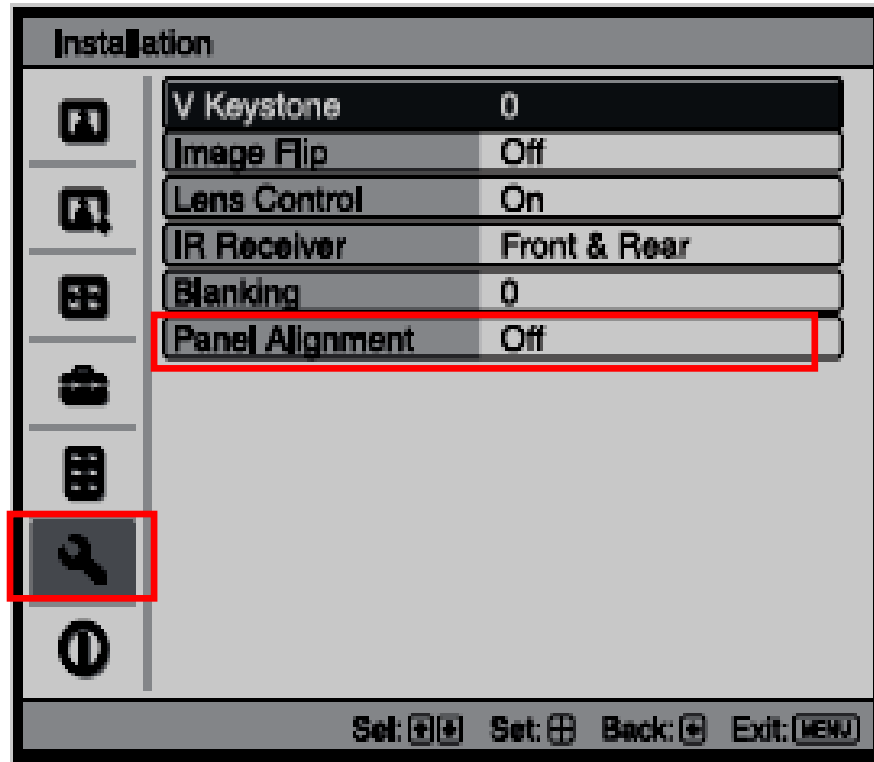

Reduce RGB Ghosting (kills focus, edge detail, texture)

Zone Picture Alignment

153 Zones of Independent Convergence

Adjustable range of Panel Alignment function

This feature allows you to sharpen edges by alignment of Red and Blue pixels to Green

Zone Panel Alignment

153 separate Zone adjustments

20 Steps of 1/10 pixel

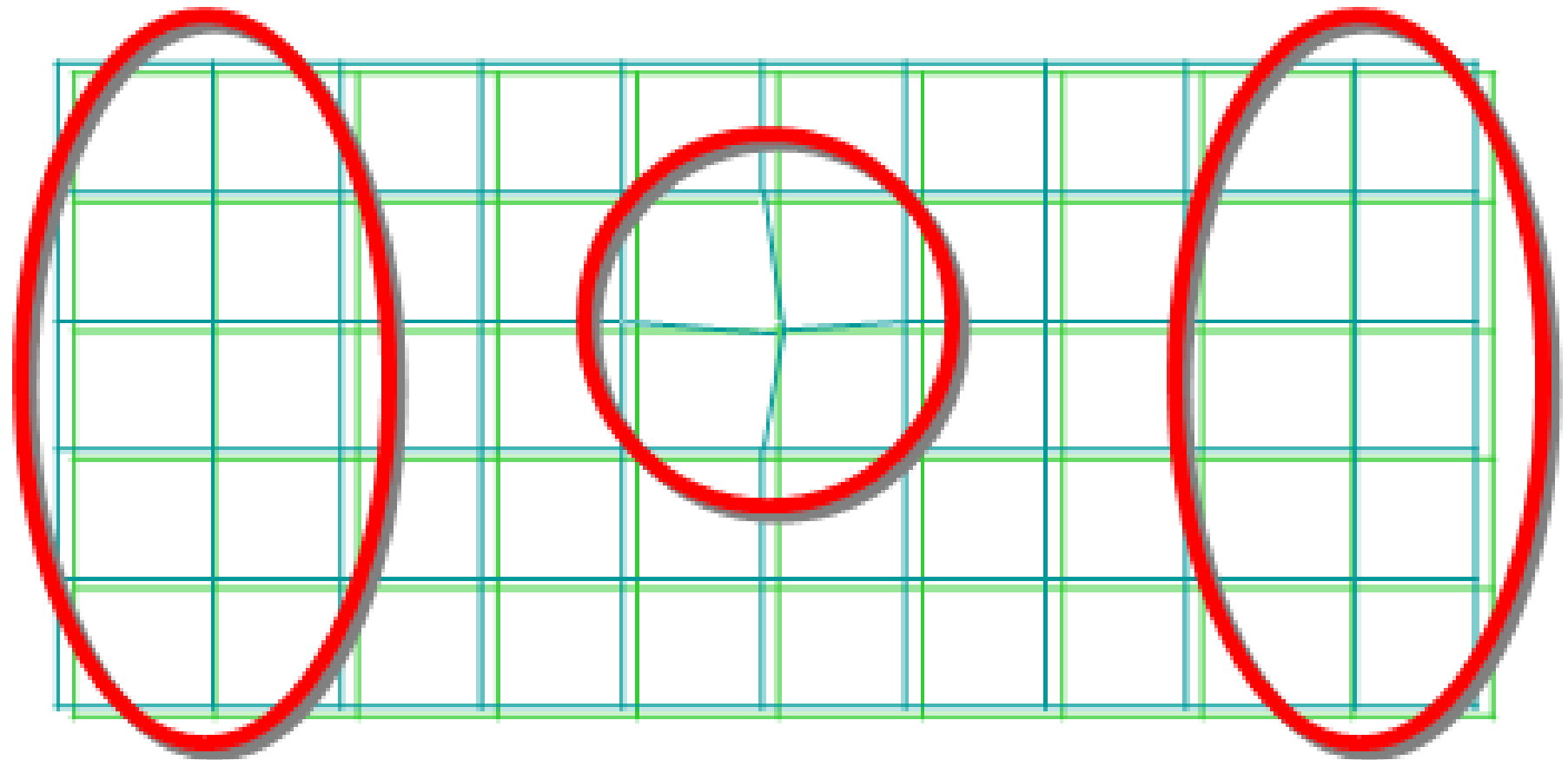

Sony Pre-Calibrated Picture Modes

Each has special Gamma, Color Space, & Color Temp presets

- Cinema Film 1: the highly dynamic and clear images typical of master positive film.
- Cinema Film 2: reproducing the rich tone and color typical of a movie theater.
- Cinema Digital: cinema like images similar to DCI specifications.
- Reference: a purist's image, with minimal adjustment.
- TV: TV programs, sports, concerts.
- Photo: Ideal for still images from a digital camera.
- Game: For gaming, with well-modulated colors and fast response.

Bright Modes for Semi lit Rooms

- Bright Cinema: for movies in a bright environment, such as a living room.
- Bright TV: For TV programs, sports, concerts, etc. in a bright environment.

Independent 2D/3D Presets and Memories

Each picture mode is separately pre-calibrated & stored for 2D / 3D content.

Picture Position

Electronic Masking

Currently there are 2 methods to increase the image size, & eliminate the black bars:

1. Use an anamorphic lens (Expensive)
2. Adjust lens zoom and shift manually (Tedious)

NOW you can store and recall the ideal lens settings, with 5 different position memories, including: 1.78:1, 1.85:1, 2.35:1, and 2 additional customizable options

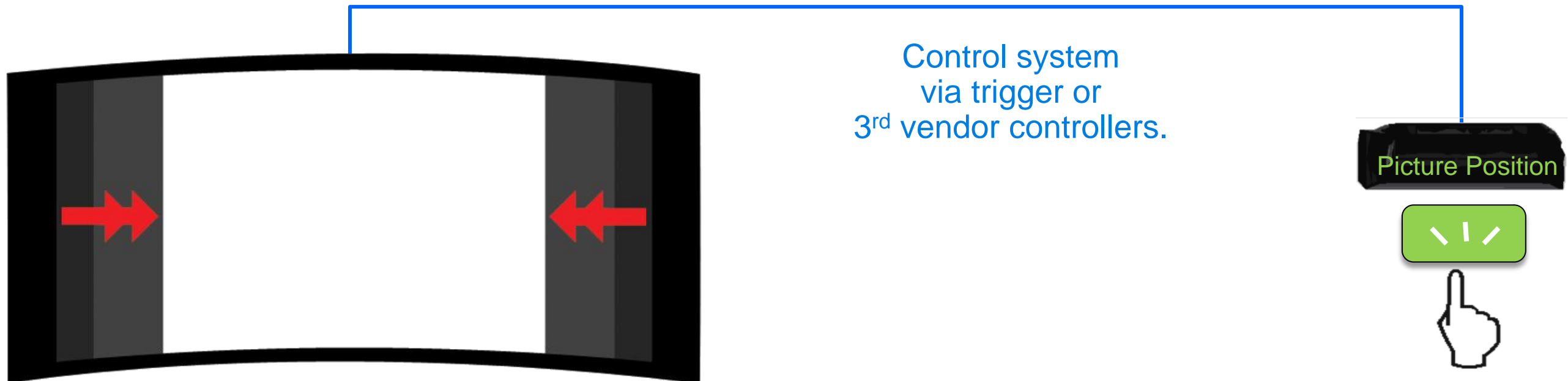

Picture Position

Applications

5 addressable memories for specific formats/memorized lens positions

Change lens zoom and shift between different formats easily

- Zoom to eliminate most black bars
- Zoom to anamorphic (without extra lens) on 2.35:1 screen
- Zoom from 16:9 to 1.85:1 and back
- Zoom from native 4K (4096 x 2160) to scaled 4K (3840 x 2160)
- Shift memory to keep image vertically centered on screen
- Shift memory to allow for certain closed captions or text
- Vertical Center & Size add flexibility for caption & aspect precision

(Note: Dependent on throw distance and Zoom/Shift range available)

Picture Position

New Test Pattern

Lens pattern modified to support Picture Position

The dashed lines indicate 2.35:1, 1.85:1, 4:3 as below

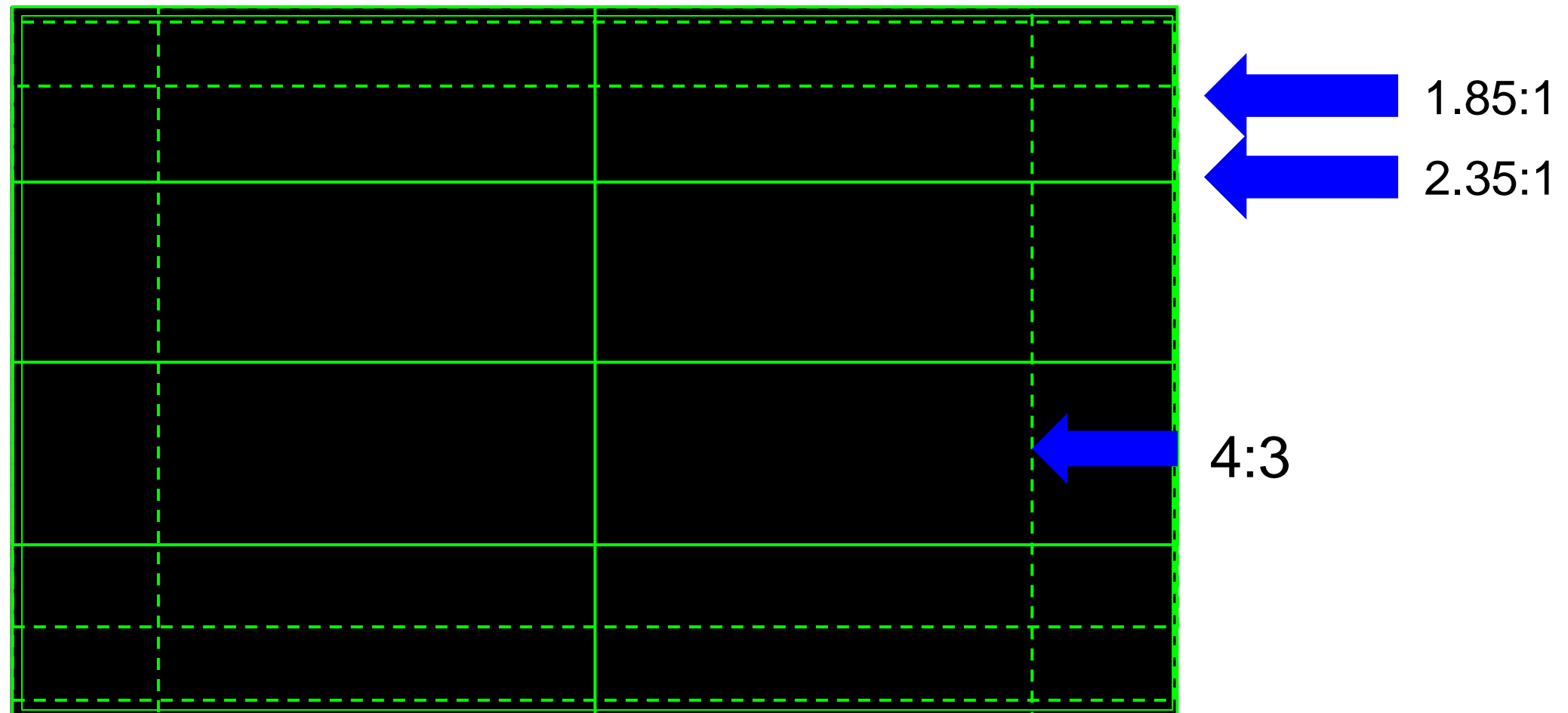

Presets for Theaters and Semi-lit Rooms

Can be used in rooms with ambient light or darkened home theater

Bright Mode

For ambient light viewing

“sRGB”

Max. lumen &
Standard
color gamut

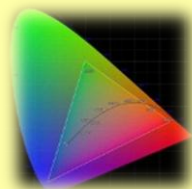

Sports



Games

Cinema Mode

For dark room viewing

“DCI”

Dimming &
Wide color
gamut

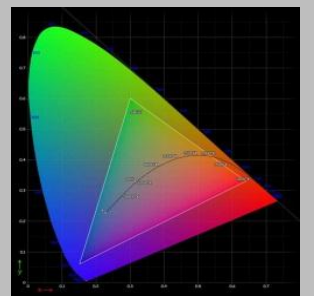

Cinema



Photos / Art

Gamma Control with new more precise Menu

1.8: Brighter picture overall.

2.0

2.1

2.2

2.4

2.6: Darker picture overall.



Gamma 7: Brightens dark areas with expanded gradation.

Gamma 8: Emphasizes contrast slightly.

Gamma 9: Emphasizes contrast slightly more.

Gamma 10: Simulates the gamma curve of film.

Off: Gamma Correction is not applied.

Built-In-Transmitter

For Less than 15' distance from screen
and Less than 120" screen size



TMR-PJ 1 Optional Wired Transmitter

For use in larger theaters
Connects via CAT5/CAT7



TDG-PJ1 3D Glasses

Quick charge w/ USB
Lighter w/ reduced ghosting



3D Viewing Adjustments

Brightness

Adjusts the Duty Cycle of 3D glasses, therefore brightness

2 Modes

HIGH or
STANDARD

3D Depth Adjustment

Vary the Depth of the 3D effect

Note: Depending on contents, crosstalk may be more visible at “-2”.
For demo purposes, “0” level is recommended

Depth	-2	-1	0	+1	+2
	Front		Normal		Deep

3D Compatible Signal Formats

Standards>	HDMI 1.4a	Extra
<p>Signal and Format Compatibility ></p>	<p>1080/24p FP, O/U Blu Ray</p> <p>1080/60p, 50p SBS, O/U</p> <p>1080/60i, 50i SBS (Broadcast)</p> <p>720/60p, 50p FP (Gaming), O/U</p>	<p>720/60p SBS</p> 

FP: Frame Packing

SBS: Side by Side

O/U: Over-Under

Throw Distance/Lens Calculator

SONY		VPL-VW1000ES Lens Calculator							4K		
Screen Type		16:9 QFHD 3840 x 2160 (4x1080P)			17:9 Full 4K 4096 x 2160			2.35:1 Wide 4096 x 1742			
Input Data Type:		Enter 1 Dimension in appropriate column. Press Enter. Calculations appear below in same column.									
		Screen Dimensions in Inches									
Inches		16:9 Width	16:9 Height	16:9 Diagonal	17:9 Width	17:9 Height	17:9 Diagonal	2.35:1 Width	2.35:1 Height	2.35:1 Diagonal	
Screen Diagonal in Inches		88.3	86.9	60.0	300.0	300.1	60.0	57.6	288.1	57.6	
Screen Height in Inches		43.3	42.6	29.4	140.3	140.4	28.1	22.6	112.8	22.6	
Screen Width in Inches		77.0	75.7	52.3	265.1	265.2	53.0	53.0	265.1	53.0	
		↑ Enter Width ↓	↑ Enter Height ↓	↑ Enter Diagonal ↓	↑ Enter Width ↓	↑ Enter Height ↓	↑ Enter Diagonal ↓	↑ Enter Width ↓	↑ Enter Height ↓	↑ Enter Diagonal ↓	
Calculations		Throw Distance to Lens in Inches (+/- 1 inch)									
LENS RANGE		Min:	102	101	69	338	338	65	65	337	65
		Max:	224	221	151	732	732	144	144	731	144
		For use with Picture Position (Zoomed Anamorphic):						Min Throw:	89	445	89
								Max Throw:	117	583	117
Lens Offsets in Inches		Max Vertical Offset from Top/Bottom of Screen, or Max Horizontal Offset from H Center of Screen									
Vertical Offset		Max:	13.0	12.8	8.8	42.1	42.1	8.4	11.3	56.4	11.3
Horizontal Offset		Max:	25.4	25.0	17.3	82.2	82.2	16.4	16.4	82.2	16.4
Feet		16:9 Width	16:9 Height	16:9 Diagonal	17:9 Width	17:9 Height	17:9 Diagonal	2.35:1 Width	2.35:1 Height	2.35:1 Diagonal	
Screen Diagonal in Feet		7.4	7.2	5.0	25.0	25.0	5.0	4.8	24.0	4.8	
Screen Height in Feet		3.6	3.6	2.5	11.7	11.7	2.3	1.9	9.4	1.9	
Screen Width in Feet		6.4	6.3	4.4	22.1	22.1	4.4	4.4	22.1	4.4	
Calculations		Throw Distance to Lens in Feet (+/- 0.1 ft)									
LENS RANGE		Min:	8.5	8.4	5.7	28.1	28.1	5.4	5.4	28.1	5.4
		Max:	18.7	18.4	12.6	61.0	61.0	12.0	12.0	60.9	12.0
		For use with Picture Position (Zoomed Anamorphic):						Min Throw:	7.4	37.1	7.4
								Max Throw:	9.7	48.6	9.7
Subtract 1 inch for Throw Distance to Front of Cabinet											

Input 16:9,
17:9, or 2.35:1
Screen Diagonal,
Height, or Width

Throw Distance
in inches

Lens Offsets
In inches

Throw Distance
in Feet



Picture Position
Zoom Limits



Sony Projector Simulator (PJSim)

Adobe Flash Player 10

File View Control Help

SONY
make.believe

VPL-VW1000ES



4Kx2K/2000lm

Select How to Use

Input Basic Data

Projection Distance

Shift Range Simulation

Simulation Result

Print Out

Input Basic Data

Projector

Video Projector | VPL-VW1000ES

Screen size

Aspect ratio: 17:9

Screen size: 100 inch | Diagonal

Projection image size

Aspect ratio: 17:9

Type: Type1: Screen and image are same size

Dimensions

	Screen size			Projection image size		
Diagonal	100 inch	2.54 m	8.3 feet	100 inch	2.54 m	8.3 feet
Width	88 inch	2.25 m	7.4 feet	88 inch	2.25 m	7.4 feet
Height	47 inch	1.18 m	3.9 feet	47 inch	1.18 m	3.9 feet

*There might be a tolerance in the simulation result.

Diagonal

Example

Type1: Screen and image are same size

Type2: Screen and image are same width

Type3: Screen and image are same height

BACK NEXT

Installation Ventilation

Leave about 1 foot on either side, and 1 foot away from cover.

Exhaust is to the rear.

Leave at least 2 inches clearance in back.

Wall could get very hot!

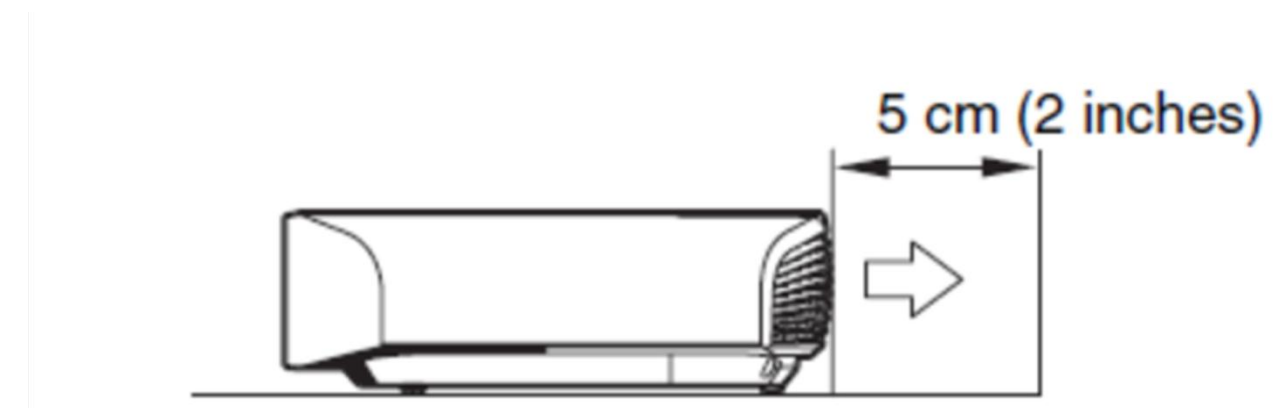
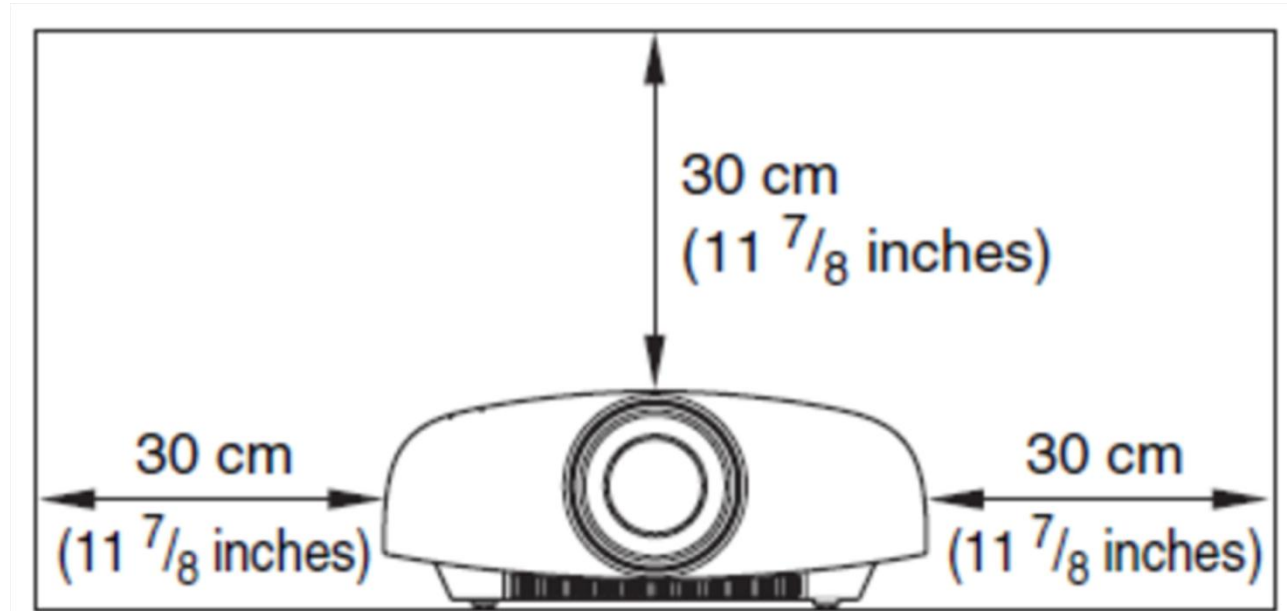

Integration Partners



*Plus: IP Control through Ethernet port!
& Dual Programmable 12 V. Triggers!*

Home Theater Magazine (Tom Norton)

Top Pick award!

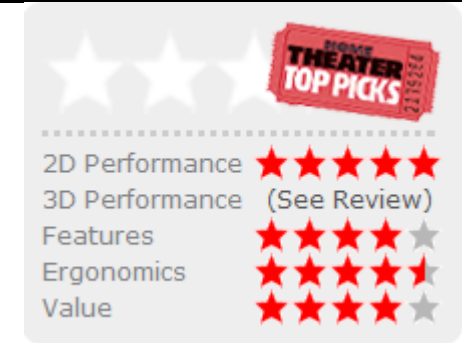

“Given a good 1920 x 1080 HD source, the projector produced some of the best 2D images I’ve yet seen...To see such resolution from conventional HD material on a screen this large is simply jaw dropping.”

“I had no complaints at all about the projector’s visible resolution from a normal viewing distance. The resolution was so good, in fact, that I could easily spot subtle focus variations in the material—more common than you’d think in most movies”

“The Sony’s blacks were respectable in its fixed iris settings but exceptional in the Auto Full dynamic mode.”

“As I’ve noted before, no one does dynamic irises better than Sony.”

The most obvious benefit I saw in the provided 4K material was how well it combined natural smoothness and detail—two qualities that are often seen as incompatible. Enhanced detail is usually what grabs our eyes first, and in that respect, the Sony certainly promises to deliver the right 4K stuff.

VPLVW1000ES: Flagship Performance Summary

30% stronger 3D internal sync emitter (vs. VW90 & 95ES)

50% stronger 3D external sync from optional emitter (vs. 2010 emitter)

500 times the contrast of the Q004 (up to 1 Million:1 Dynamic contrast)

80% screen height lens shift (double previous top-of-screen offset)

100% wider TD zoom range up from 1.39-2.1 to 1.27-2.73 (vs. 2010 models)

Four times the resolution of 1080P (8.8 million pixels)

Super resolution scaling combined with Sony's best FPJ processor ever

Special high resolution 4K optimized precision lens

Picture Position Lens Zoom/Shift Memory

ES MARKET TRAINING SPECIALISTS

TERRITORY MAP

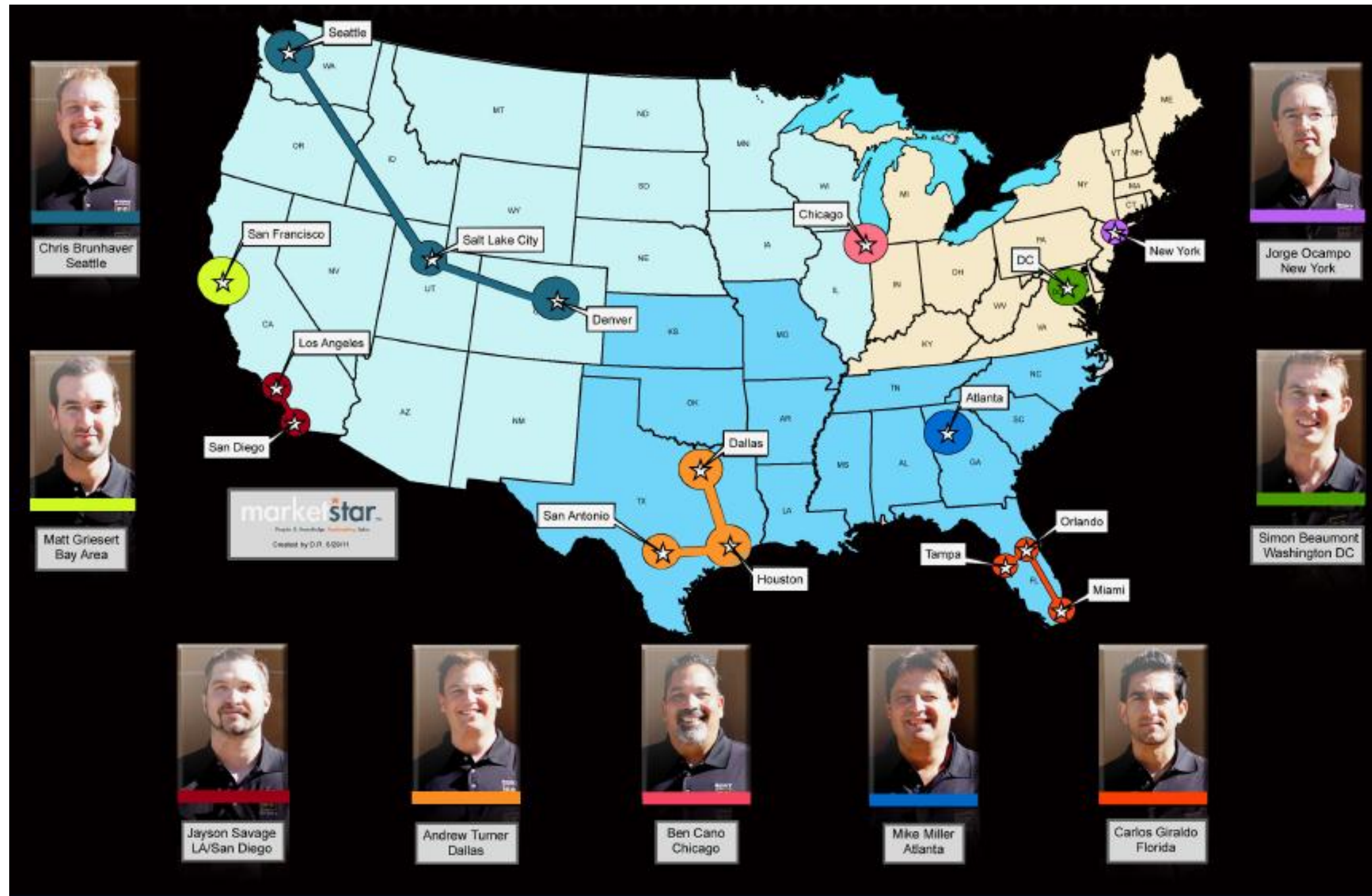

ES MARKET TRAINING SPECIALISTS



Product Experts
Located in San Diego, CA
CEDIA trained
Control4 & AMX Certified
Installers

Full lab of equipment for
testing & troubleshooting

installsupport@am.sony.com

CONTACT INFORMATION

Install Support Team
Cedia Trained, San Diego Based, Product Specialists
1-866-924-7669
installsupport@am.sony.com
www.sony.com/ES

Amy Escobio
Product Manager
Amy.Escobio@am.sony.com

Rob McDonough
Senior Support Engineer
Rob.McDonough@am.sony.com

Jon Lin
Business Manager
Jonathan.Lin@am.sony.com

SONY

make.believe