

1U/2U/3U/4U 19in Steel Vertical Wall Mount Equipment Rack Bracket

RK119WALLV/RK219WALLV/RK319WALLV/RK419WALLV

- DE: Bedienungsanleitung - de.startech.com
- FR: Guide de l'utilisateur - fr.startech.com
- ES: Guía del usuario - es.startech.com
- IT: Guida per l'uso - it.startech.com
- NL: Gebruiksaanwijzing - nl.startech.com
- PT: Guia do usuário - pt.startech.com

Packaging Contents

- 1x RKx19WALLV rack
- 1x Vertical Wall Mount Bracket
- 4x Cage nuts and screws (4 Each)
- 6x Self Tapping Wood Screws - 3/16" x 1 1/2"

The RKx19WALLV unit can be mounted either vertically onto a wall, or horizontally under a desk for example.

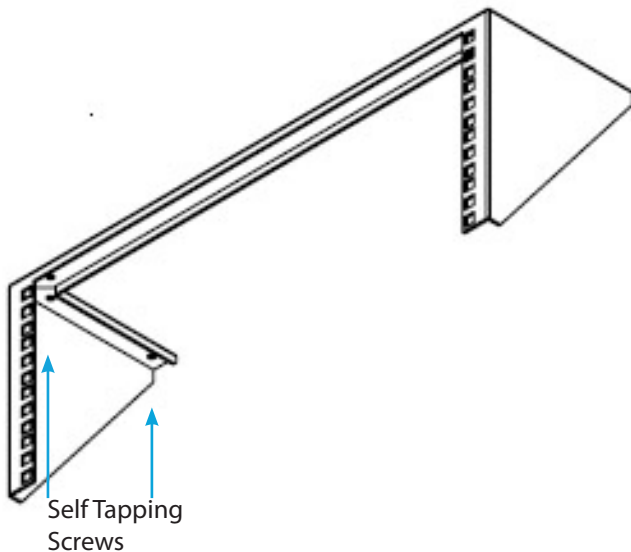
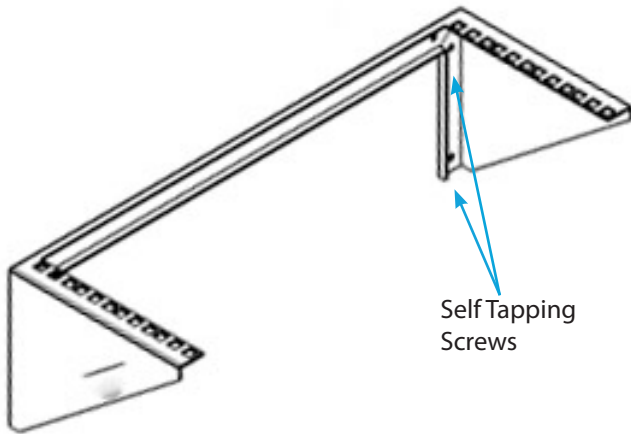

*actual product may vary from photos

1. Make sure the mounting surface is sturdy enough to support the weight of the RKx19WALLV rack, plus 1. all of a equipment to be installed into the rack. Test fit the rack to the surface to ensure proper fit and mark the 6 mounting points.
2. Use the provided self-tapping screws (for wood surfaces only) to affix the RKx19WALLV unit to the 2. mounting surface.
3. Once the rack is properly mounted to the surface, rackmountable equipment can be installed. Use the 3. supplied square cage nuts to provide the mounting points for the rackmountable equipment, then use the supplied cabinet screws to install the equipment into the rack.

Use of Trademarks, Registered Trademarks, and other Protected Names and Symbols

This manual may make reference to trademarks, registered trademarks, and other protected names and/or symbols of third-party companies not related in any way to StarTech.com. Where they occur these references are for illustrative purposes only and do not represent an endorsement of a product or service by StarTech.com, or an endorsement of the product(s) to which this manual applies by the third-party company in question. Regardless of any direct acknowledgement elsewhere in the body of this document, StarTech.com hereby acknowledges that all trademarks, registered trademarks, service marks, and other protected names and/or symbols contained in this manual and related documents are the property of their respective holders.

Technical Support

StarTech.com's lifetime technical support is an integral part of our commitment to provide industry-leading solutions. If you ever need help with your product, visit www.startech.com/support and access our comprehensive selection of online tools, documentation, and downloads.

For the latest drivers/software, please visit www.startech.com/downloads

Warranty Information

This product is backed by a lifetime warranty.

In addition, StarTech.com warrants its products against defects in materials and workmanship for the periods noted, following the initial date of purchase. During this period, the products may be returned for repair, or replacement with equivalent products at our discretion. The warranty covers parts and labor costs only. StarTech.com does not warrant its products from defects or damages arising from misuse, abuse, alteration, or normal wear and tear.

Limitation of Liability

In no event shall the liability of StarTech.com Ltd. and StarTech.com USA LLP (or their officers, directors, employees or agents) for any damages (whether direct or indirect, special, punitive, incidental, consequential, or otherwise), loss of profits, loss of business, or any pecuniary loss, arising out of or related to the use of the product exceed the actual price paid for the product. Some states do not allow the exclusion or limitation of incidental or consequential damages. If such laws apply, the limitations or exclusions contained in this statement may not apply to you.