

ideapad 310

ideapad 310-14ISK

ideapad 310-15ISK

ideapad 310 Touch-15ISK

ideapad 310-15ABR

Hardware Maintenance Manual

Lenovo[™]

Note:

Before using this information and the product it supports, be sure to read the general information under “Notices” on page 107.

First Edition (June 2016)

© Copyright Lenovo 2016. All rights reserved.

LENOVO products, data, computer software, and services have been developed exclusively at private expense and are sold to governmental entities as commercial items as defined by 48 C.F.R. 2.101 with limited and restricted rights to use, reproduction and disclosure.

LIMITED AND RESTRICTED RIGHTS NOTICE: If products, data, computer software, or services are delivered pursuant a General Services Administration “GSA” contract, use, reproduction, or disclosure is subject to restrictions set forth in Contract No. GS-35F-05925.

© 2016 Lenovo

Contents

About this manual	iv	Lenovo ideapad 310-14ISK/ideapad 310-15ISK/ideapad 310 Touch-15ISK/ideapad 310-15ABR	27
Safety information	1	Specifications	27
General safety	2	Status indicators.....	30
Electrical safety	3	Hotkeys	32
Safety inspection guide	5	FRU replacement notices	33
Handling devices that are sensitive to electrostatic discharge.....	6	Screw notices	33
Grounding requirements	6	Removing and replacing an FRU	34
Safety notices: multilingual translations	7	1010 Hard disk drive(HDD) slot compartment cover.....	35
Laser compliance statement.....	14	1020 Hard disk drive	36
Important service information	16	1030 Memory/Mini PCI Express Card slot compartment cover and DIMM.....	39
Strategy for replacing FRUs.....	16	1040 PCI Express Mini Card for wireless LAN/WAN	41
Strategy for replacing a hard disk drive	17	1050 Optical drive.....	43
Important notice for replacing a system board	17	1060 Keyboard bezel	44
Important information about replacing RoHS compliant FRUs	18	1070 System board	46
General checkout	19	1080 Fan assembly and Heat Sink assembly.....	50
What to do first	20	1090 LCD unit.....	52
Power system checkout	21	1100 Battery pack	54
Checking the AC adapter.....	21	1110 Speakers, base cover, USB board and ODD transfer board.....	56
Checking operational charging	22	1120 LCD front bezel	62
Checking the battery pack	22	1130 LCD panel and LCD cable.....	63
Related service information	23	1140 LCD hinges	65
Restoring the factory contents by using Recovery Disc Set	23	1150 Integrated camera	66
Start Recovery Disc (one disc).....	23	1160 Antenna assembly and LCD cover	67
Operating System Recovery Disc (one or more discs)	23	Locations	68
Applications and Drivers Recovery Disc (one or more discs).....	23	Front view	68
Supplemental Recovery Disc	23	Bottom and Left-side view	70
Passwords.....	24	Right-side view	71
Power-on password	24	Parts list.....	72
Hard-disk password	24	Overall.....	73
Supervisor password	24	LCD FRUs.....	94
Power management	25	Miscellaneous parts	98
Screen blank state	25	Screws.....	99
Putting your computer to sleep.....	25	AC adapters.....	100
Shutting down the computer.....	26	Notices	107
		Trademarks	108

About this manual

This manual contains service and reference information for the following Lenovo product:

Lenovo ideapad 310-14ISK/ideapad 310-15ISK/ideapad 310 Touch-15ISK/ideapad 310-15ABR

Use this manual to troubleshoot problems.

The manual is divided into the following sections:

- The common sections provide general information, guidelines, and safety information required for servicing computers.
- The product-specific section includes service, reference, and product-specific parts information.

Important:

This manual is intended only for trained servicers who are familiar with Lenovo products. Use this manual to troubleshoot problems effectively. Before servicing a Lenovo product, make sure to read all the information under "Safety information" on page 1 and "Important service information" on page 16.

Safety information

This chapter presents the following safety information that you need to get familiar with before you service a Lenovo computer:

- “General safety” on page 2
- “Electrical safety” on page 3
- “Safety inspection guide” on page 5
- “Handling devices that are sensitive to electrostatic discharge” on page 6
- “Grounding requirements” on page 6
- “Safety notices: multilingual translations” on page 7
- “Laser compliance statement” on page 14

General safety

Follow these rules below to ensure general safety:

- Observe a good housekeeping in the area where the machines are put during and after the maintenance.
- When lifting any heavy object:
 1. Make sure that you can stand safely without slipping.
 2. Distribute the weight of the object equally between your feet.
 3. Use a slow lifting force. Never move suddenly or twist when you attempt to lift it.
 4. Lift it by standing or pushing up with your leg muscles; this action could avoid the strain from the muscles in your back. Do not attempt to lift any object that weighs more than 16 kg (35 lb) or that you think is too heavy for you.
- Do not perform any action that causes hazards to the customer, or that makes the machine unsafe.
- Before you start the machine, make sure that other service representatives and the customer are not in a hazardous position.
- Please remove covers and other parts in a safe place, away from all personnel, while you are servicing the machine.
- Keep your toolcase away from walk areas so that other people will not trip it over.
- Do not wear loose clothing that can be trapped in the moving parts of the machine. Make sure that your sleeves are fastened or rolled up above your elbows. If your hair is long, fasten it.
- Insert the ends of your necktie or scarf inside clothing or fasten it with the nonconductive clip, about 8 centimeters (3 inches) from the end.
- Do not wear jewelry, chains, metal-frame eyeglasses, or metal fasteners for your clothing.

Attention: Metal objects are good electrical conductors.
- Wear safety glasses when you are hammering, drilling, soldering, cutting wire, attaching springs, using solvents, or working in any other conditions that may be hazardous to your eyes.
- After service, reinstall all safety shields, guards, labels, and ground wires. Replace any safety device that is worn or defective.
- Reinstall all covers correctly before returning the machine to the customer.
- Fan louvers on the machine help to prevent the overheating of internal components. Do not obstruct fan louvers or cover them with labels or stickers.

Electrical safety

Observe the following rules when working on electrical equipments.

Important:

Use only approved tools and test equipments. Some hand tools have handles covered with a soft material that does not insulate you when working with live electrical currents.

Many customers have rubber floor mats near their machines that contain small conductive fibers to decrease electrostatic discharges. Do not use such kind of mat to protect yourself from electrical shock.

- Find the room emergency power-off (EPO) switch, disconnecting switch, or electrical outlet. If an electrical accident occurs, you can then operate the switch or unplug the power cord quickly.
- Do not work alone under hazardous conditions or near the equipment that has hazardous voltages.
- Disconnect all power before:
 - Performing a mechanical inspection
 - Working near power supplies
 - Removing or installing main units
- Before you start to work on the machine, unplug the power cord. If you cannot unplug it, ask the customer to power-off the wall box that supplies power to the machine, and to lock the wall box in the off position.
- If you need to work on a machine that has exposed electrical circuits, observe the following precautions:
 - Ensure that another person, familiar with the power-off controls, is near you.

Attention: Another person must be there to switch off the power, if necessary.
 - Use only one hand when working with powered-on electrical equipment; keep the other hand in your pocket or behind your back.

Attention: An electrical shock can occur only when there is a complete circuit. By observing the above rule, you may prevent a current from passing through your body.
 - When using testers, set the controls correctly and use the approved probe leads and accessories for that tester.
 - Stand on suitable rubber mats (obtained locally, if necessary) to insulate you from grounds such as metal floor strips and machine frames.

Observe the special safety precautions when you work with very high voltages; instructions for these precautions are in the safety sections of maintenance information. Be extremely careful when you measure the high voltages.

- Regularly inspect and maintain your electrical hand tools for safe operational condition.
- Do not use worn or broken tools and testers.
- Never assume that power has been disconnected from a circuit. First, check it to make sure that it has been powered off.

// *Lenovo ideapad 310-14ISK/ideapad 310-15ISK/ideapad 310 Touch-15ISK/ideapad 310-15ABR Hardware Maintenance Manual*

- Always look carefully for possible hazards in your work area. Examples of these hazards are moist floors, nongrounded power extension cables, power surges, and missing safety grounds.
- Do not touch live electrical circuits with the reflective surface of a plastic dental mirror. The surface is conductive; such touching can cause personal injury and machine damage.
- Do not service the following parts with the power on when they are removed from their normal operating places in a machine:
 - Power supply units
 - Pumps
 - Blowers and fans
 - Motor generatorsand similar units. (This practice ensures correct grounding of the units.)
- If an electrical accident occurs:
 - Use caution: do not become a victim yourself.
 - Switch off the power.
 - Send the victim to get medical aid.

Safety inspection guide

The purpose of this inspection guide is to assist you in identifying potential unsafe conditions. As each machine was designed and built, required safety items were installed to protect users and service personnel from injury. This guide addresses only those items. You should use good judgment to identify potential safety hazards due to attachment of non-Lenovo features or options not covered by this inspection guide.

If any unsafe conditions are present, you must determine how serious the apparent hazard could be and whether you can continue without first correcting the problem.

Consider these conditions and the safety hazards they present:

- Electrical hazards, especially primary power (primary voltage on the frame can cause serious or fatal electrical shock)
- Explosive hazards, such as a damaged CRT face or a bulging capacitor
- Mechanical hazards, such as loose or missing hardware

To determine whether there are any potential unsafe conditions, use the following checklist at the beginning of every service task. Begin the checks with the power off, and the power cord disconnected.

Checklist:

1. Check exterior covers for damage (loose, broken, or sharp edges).
2. Turn off the computer. Disconnect the power cord.
3. Check the power cord for:
 - a. A third-wire ground connector in good condition. Use a meter to measure third-wire ground continuity for 0.1 ohm or less between the external ground pin and the frame ground.
 - b. The power cord should be the type specified in the parts list.
 - c. Insulation must not be frayed or worn.
4. Check for cracked or bulging batteries.
5. Remove the cover.
6. Check for any obvious non-Lenovo alterations. Use good judgment as to the safety of any non-Lenovo alterations.
7. Check inside the unit for any obvious unsafe conditions, such as metal filings, contamination, water or other liquids, or signs of fire or smoke damage.
8. Check for worn, frayed, or pinched cables.
9. Check that the power-supply cover fasteners (screws or rivets) have not been removed or tampered with.

Handling devices that are sensitive to electrostatic discharge

Any computer part containing transistors or integrated circuits (ICs) should be considered sensitive to electrostatic discharge (ESD). ESD damage can occur when there is a difference in charge between objects. Protect against ESD damage by equalizing the charge so that the machine, the part, the work mat, and the person handling the part are all at the same charge.

Notes:

1. Use product-specific ESD procedures when they exceed the requirements noted here.
2. Make sure that the ESD protective devices you use have been certified (ISO 9000) as fully effective.

When handling ESD-sensitive parts:

- Keep the parts in protective packages until they are inserted into the product.
- Avoid contact with other people.
- Wear a grounded wrist strap against your skin to eliminate static on your body.
- Prevent the part from touching your clothing. Most clothing is insulative and retains a charge even when you are wearing a wrist strap.
- Use the black side of a grounded work mat to provide a static-free work surface. The mat is especially useful when handling ESD-sensitive devices.
- Select a grounding system, such as those listed below, to provide protection that meets the specific service requirement.

Notes:

The use of a grounding system to guard against ESD damage is desirable but not necessary.

- Attach the ESD ground clip to any frame ground, ground braid, or green-wire ground.
- When working on a double-insulated or battery-operated system, use an ESD common ground or reference point. You can use coax or connector-outside shells on these systems.
- Use the round ground prong of the ac plug on ac-operated computers.

Grounding requirements

Electrical grounding of the computer is required for operator safety and correct system function. Proper grounding of the electrical outlet can be verified by a certified electrician.

Safety notices: multilingual translations

The safety notices in this section are provided in English, French, German, Hebrew, Italian, Japanese, and Spanish.

Safety notice 1

Before the computer is powered on after FRU replacement, make sure all screws, springs, and other small parts are in place and are not left loose inside the computer. Verify this by shaking the computer and listening for rattling sounds. Metallic parts or metal flakes can cause electrical shorts.

Avant de remettre l'ordinateur sous tension après remplacement d'une unité en clientèle, vérifiez que tous les ressorts, vis et autres pièces sont bien en place et bien fixées. Pour ce faire, secouez l'unité et assurez-vous qu'aucun bruit suspect ne se produit. Des pièces métalliques ou des copeaux de métal pourraient causer un court-circuit.

Bevor nach einem FRU-Austausch der Computer wieder angeschlossen wird, muß sichergestellt werden, daß keine Schrauben, Federn oder andere Kleinteile fehlen oder im Gehäuse vergessen wurden. Der Computer muß geschüttelt und auf Klappergeräusche geprüft werden. Metallteile oder-splitter können Kurzschlüsse erzeugen.

לפני הפעלת המחשב לאחר החלפת FRU יש לוודא שכל הברגים, הקפיצים, וחלקים קטנים אחרים נמצאים במקומם ואינם חופשיים לזוז בתוך המחשב. כדי לוודא זאת, יש ללטלט את המחשב ולהקשיב לגילוי קולות שקשוק. חלקי או שבבי מתכת עלולים לגרום לקצרים חשמליים.

Prima di accendere l'elaboratore dopo che é stata effettuata la sostituzione di una FRU, accertarsi che tutte le viti, le molle e tutte le altre parti di piccole dimensioni siano nella corretta posizione e non siano sparse all'interno dell'elaboratore. Verificare ciò scuotendo l'elaboratore e prestando attenzione ad eventuali rumori; eventuali parti o pezzetti metallici possono provocare cortocircuiti pericolosi.

FRUの交換後、コンピュータの電源を入れる前に、ねじ、バネ、その他の小さな部品がすべて正しい位置にあり、またコンピュータの内部で緩んでいないことを確認してください。これを確認するには、コンピュータを振って、カチャカチャと音がしないか確かめませう。金属部品や金属破片はショートの原因になることがあります。

Antes de encender el sistema despues de sustituir una FRU, compruebe que todos los tornillos, muelles y demás piezas pequeñas se encuentran en su sitio y no se encuentran sueltas dentro del sistema. Compruébelo agitando el sistema y escuchando los posibles ruidos que provocarían. Las piezas metálicas pueden causar cortocircuitos eléctricos.

Safety notice 2

DANGER

Some standby batteries contain a small amount of nickel and cadmium. Do not disassemble a standby battery, recharge it, throw it into fire or water, or short-circuit it. Dispose of the battery as required by local ordinances or regulations. Use only the battery in the appropriate parts listing. Use of an incorrect battery can result in ignition or explosion of the battery.

Certaines batteries de secours contiennent du nickel et du cadmium. Ne les démontez pas, ne les rechargez pas, ne les exposez ni au feu ni à l'eau. Ne les mettez pas en court-circuit. Pour les mettre au rebut, conformez-vous à la réglementation en vigueur. Lorsque vous remplacez la pile de sauvegarde ou celle de l'horloge temps réel, veillez à n'utiliser que les modèles cités dans la liste de pièces détachées adéquate. Une batterie ou une pile inappropriée risque de prendre feu ou d'exploser.

Die Bereitschaftsbatterie, die sich unter dem Diskettenlaufwerk befindet, kann geringe Mengen Nickel und Cadmium enthalten. Sie darf nicht zerlegt, wiederaufgeladen, kurzgeschlossen, oder Feuer oder Wasser ausgesetzt werden. Bei der Entsorgung die örtlichen Bestimmungen für Sondermüll beachten. Beim Ersetzen der Bereitschafts- oder Systematterie nur Batterien des Typs verwenden, der in der Ersatzteilliste aufgeführt ist. Der Einsatz falscher Batterien kann zu Entzündung oder Explosion führen.

סוללות המתנה מסוימות מכילות כמות קטנה של ניקל וקדמיום. אין למרק סוללת המתנה, לטעון אותה מחדש, להשליך אותה לאש או למים או לקצר אותה. יש לטפל את הסוללה כדורש על ידי התקנות והחוקים המקומיים. יש להשתמש רק בסוללה המופיעה ברשימת החלקים המתאימה. שימוש בסוללה לא מתאימה עלול לגרום להצתה או התפוצצות של הסוללה.

Alcune batterie di riserva contengono una piccola quantità di nichel e cadmio. Non smontarle, ricaricarle, gettarle nel fuoco o nell'acqua né cortocircuitarle. Smaltirle secondo la normativa in vigore (DPR 915/82, successive disposizioni e disposizioni locali). Quando si sostituisce la batteria dell'RTC (real time clock) o la batteria di supporto, utilizzare soltanto i tipi inseriti nell'appropriato Catalogo parti. L'impiego di una batteria non adatta potrebbe determinare l'incendio o l'esplosione della batteria stessa.

予備バッテリーの中には少量のニッケルとカドミウムが含まれているものがあります。したがって、予備バッテリーの分解、再充電、火または水の中への投棄、またはショートさせることは決して行わないでください。バッテリーを廃棄する場合は地方自治体の条例に従ってください。適切なパーツ・リストにあるバッテリーだけを使用してください。誤ったバッテリーを使用すると、バッテリーが発火したり、爆発したりすることがあります。

Algunas baterías de reserva contienen una pequeña cantidad de níquel y cadmio. No las desmonte, ni recargue, ni las eche al fuego o al agua ni las cortocircuite. Deséchelas tal como dispone la normativa local. Utilice sólo baterías que se encuentren en la lista de piezas. La utilización de una batería no apropiada puede provocar la ignición o explosión de la misma.

Safety notice 3

⚠ DANGER

The battery pack contains small amounts of nickel. Do not disassemble it, throw it into fire or water, or short-circuit it. Dispose of the battery pack as required by local ordinances or regulations. Use only the battery in the appropriate parts listing when replacing the battery pack. Use of an incorrect battery can result in ignition or explosion of the battery.

La batterie contient du nickel. Ne la démontez pas, ne l'exposez ni au feu ni à l'eau. Ne la mettez pas en court-circuit. Pour la mettre au rebut, conformez-vous à la réglementation en vigueur. Lorsque vous remplacez la batterie, veillez à n'utiliser que les modèles cités dans la liste de pièces détachées adéquate. En effet, une batterie inappropriée risque de prendre feu ou d'exploser.

Akkus enthalten geringe Mengen von Nickel. Sie dürfen nicht zerlegt, wiederaufgeladen, kurzgeschlossen, oder Feuer oder Wasser ausgesetzt werden. Bei der Entsorgung die örtlichen Bestimmungen für Sondermüll beachten. Beim Ersetzen der Batterie nur Batterien des Typs verwenden, der in der Ersatzteilliste aufgeführt ist. Der Einsatz falscher Batterien kann zu Entzündung oder Explosion führen.

מארו הסוללה מכיל כמות קטנה של ניקל וקדמיום. אין לפרק את מארו הסוללה, להשליך אותו לאש או למים או לקצר אותו. יש לשלק את מארו הסוללה הסוללה כנדרש על ידי התקנות והחוקים המקומיים. יש להשתמש רק בסוללה המופיעה ברשימת החלקים המתאימה בזמן החלפת מארו הסוללה. שימוש בסוללה לא מתאימה עלול לגרום לנזקה או התפוצצות של הסוללה.

La batteria contiene piccole quantità di nichel. Non smontarla, gettarla nel fuoco o nell'acqua né cortocircuitarla. Smaltirla secondo la normativa in vigore (DPR 915/82, successive disposizioni e disposizioni locali). Quando si sostituisce la batteria, utilizzare soltanto i tipi inseriti nell'appropriato Catalogo parti. L'impiego di una batteria non adatta potrebbe determinare l'incendio o l'esplosione della batteria stessa.

バッテリー・パックには少量のニッケルが含まれています。バッテリー・パックを分解したり、火または水の中に投げ込んだり、ショートさせないでください。バッテリー・パックの廃棄にあたっては、地方自治体の条例または規則に従ってください。バッテリー・パックを交換するときは、適切なパーツ・リストにあるバッテリーだけを使用してください。誤ったバッテリーを使用すると、バッテリーが発火したり、爆発したりすることがあります。

Las baterías contienen pequeñas cantidades de níquel. No las desmonte, ni recargue, ni las eche al fuego o al agua ni las cortocircuite. Deséchelas tal como dispone la normativa local. Utilice sólo baterías que se encuentren en la lista de piezas al sustituir la batería. La utilización de una batería no apropiada puede provocar la ignición o explosión de la misma.

Safety notice 4

DANGER

The lithium battery can cause a fire, an explosion, or a severe burn. Do not recharge it, remove its polarized connector, disassemble it, heat it above 100°C (212°F), incinerate it, or expose its cell contents to water. Dispose of the battery as required by local ordinances or regulations. Use only the battery in the appropriate parts listing. Use of an incorrect battery can result in ignition or explosion of the battery.

La pile de sauvegarde contient du lithium. Elle présente des risques d'incendie, d'explosion ou de brûlures graves. Ne la rechargez pas, ne retirez pas son connecteur polarisé et ne la démontez pas. Ne l'exposez pas à une température supérieure à 100°C, ne la faites pas brûler et n'en exposez pas le contenu à l'eau. Mettez la pile au rebut conformément à la réglementation en vigueur. Une pile inappropriée risque de prendre feu ou d'exploser.

Die Systematterie ist eine Lithiumatterie. Sie kann sich entzünden, explodieren oder schwere Verbrennungen hervorrufen. Batterien dieses Typs dürfen nicht aufgeladen, zerlegt, über 100 C erhitzt oder verbrannt werden. Auch darf ihr Inhalt nicht mit Wasser in Verbindung gebracht oder der zur richtigen Polung angebrachte Verbindungsstecker entfernt werden. Bei der Entsorgung die örtlichen Bestimmungen für Sondermüll beachten. Beim Ersetzen der Batterie nur Batterien des Typs verwenden, der in der Ersatzteilliste aufgeführt ist. Der Einsatz falscher Batterien kann zu Entzündung oder Explosion führen.

סוללת הליתיום עלולה לגרום לשריפה, להתפוצצות או לכוויות קשות. אין לטעון אותה מחדש, לטלוק את המחבר המפוצץ שלה, למפרק אותה או לחמם אותה לטמפרטורה העולה על 100 מעלות צלזיוס. אין לשרוף את הסוללה ואין לחשוף את תוכן התא למים. יש לטלוק את הסוללה כנדרש בתקנות ובחוקים המקומיים. יש להשתמש רק בסוללה המופיעה ברשימת החלקים המתאימים. שימוש בסוללה אחרת עלול לגרום לסכנת שריפה או התפוצצות.

La batteria di supporto e una batteria al litio e puo incendiarsi, esplodere o procurare gravi ustioni. Evitare di ricaricarla, smontarne il connettore polarizzato, smontarla, riscaldarla ad una temperatura superiore ai 100 gradi centigradi, incendarla o gettarla in acqua. Smaltirla secondo la normativa in vigore (DPR 915/82, successive disposizioni e disposizioni locali). L'impiego di una batteria non adatta potrebbe determinare l'incendio o l'esplosione della batteria stessa.

リチウム・バッテリーは、火災、爆発、または重症のやけどを引き起こすことがあります。バックアップ・バッテリーの充電、その極性コネクタの取り外し、バッテリー本体の分解、100°C (212°F) 以上への加熱、焼却、電池の中身を水に浸すことはしないでください。バッテリーを廃棄する場合は地方自治体の条例に従ってください。適切なパーツ・リストにあるバッテリーだけを使用してください。誤ったバッテリーを使用すると、バッテリーが発火したり、爆発したりすることがあります。

La batería de respaldo es una batería de litio y puede provocar incendios, explosiones o quemaduras graves. No la recargue, ni quite el conector polarizado, ni la desmonte, ni caliente por encima de los 100°C (212°F), ni la incinere ni exponga el contenido de sus celdas al agua. Deséchela tal como dispone la normativa local.

Safety notice 5

If the LCD breaks and the fluid from inside the LCD gets into your eyes or on your hands, immediately wash the affected areas with water at least for 15 minutes. Seek medical care if any symptoms caused by the fluid are present after washing.

Si le panneau d'affichage à cristaux liquides se brise et que vous recevez dans les yeux ou sur les mains une partie du fluide, rincez-les abondamment pendant au moins quinze minutes. Consultez un médecin si des symptômes persistent après le lavage.

Die Leuchtstoffröhre im LCD-Bildschirm enthält Quecksilber. Bei der Entsorgung die örtlichen Bestimmungen für Sondermüll beachten. Der LCD-Bildschirm besteht aus Glas und kann zerbrechen, wenn er unsachgemäß behandelt wird oder der Computer auf den Boden fällt. Wenn der Bildschirm beschädigt ist und die darin befindliche Flüssigkeit in Kontakt mit Haut und Augen gerät, sollten die betroffenen Stellen mindestens 15 Minuten mit Wasser abgespült und bei Beschwerden anschließend ein Arzt aufgesucht werden.

אם מסך הניבש הנוזלי (LCD) נשבר והנוזל מתוך המסך בא במגע עם עיניכם או ידיכם, שטפו את האזורים הנוגעים מיד במים במשך 15 דקות לפחות. פנו לקבלת עזרה רפואית אם תסמינים הנובעים מהמגע עם הנוזל נמשכים לאחר השטיפה.

Nel caso che caso l'LCD si dovesse rompere ed il liquido in esso contenuto entrasse in contatto con gli occhi o le mani, lavare immediatamente le parti interessate con acqua corrente per almeno 15 minuti; poi consultare un medico se i sintomi dovessero permanere.

LCD が破損し、LCD 中の液体が目に入ったり、手に触れたりした場合は、液体が触れた部分を少なくとも 15 分間洗い流してください。洗い流した後に、液体によって何らかの症状が現れた場合は、医師の治療を受けてください。

Si la LCD se rompe y el fluido de su interior entra en contacto con sus ojos o sus manos, lave inmediatamente las áreas afectadas con agua durante 15 minutos como mínimo. Obtenga atención medica si se presenta algún síntoma del fluido despues de lavarse.

Safety notice 6

⚠ DANGER

To avoid shock, do not remove the plastic cover that protects the lower part of the inverter card.

Afin d'éviter tout risque de choc électrique, ne retirez pas le cache en plastique protégeant la partie inférieure de la carte d'alimentation.

Aus Sicherheitsgründen die Kunststoffabdeckung, die den unteren Teil der Spannungswandlerplatine umgibt, nicht entfernen.

כדי למנוע התחשמלות, אין להסיר את מכסה הפלסטיק המגן על חלקו התחתון של הכרטיס ההפוך.

Per evitare scosse elettriche, non rimuovere la copertura in plastica che avvolge la parte inferiore della scheda invertitore.

感電を防ぐため、インバーター・カードの下部を保護しているプラスチック・カバーを外さないでください。

Para evitar descargas, no quite la cubierta de plástico que rodea la parte baja de la tarjeta invertida.

Safety notice 7

⚠ DANGER

Though the main batteries have low voltage, a shorted or grounded battery can produce enough current to burn personnel or combustible materials.

Bien que le voltage des batteries principales soit peu élevé, le court-circuit ou la mise à la masse d'une batterie peut produire suffisamment de courant pour brûler des matériaux combustibles ou causer des brûlures corporelles graves.

Obwohl Hauptbatterien eine niedrige Spannung haben, können sie doch bei Kurzschluß oder Erdung genug Strom abgeben, um brennbare Materialien zu entzünden oder Verletzungen bei Personen hervorzurufen.

אף שהסוללות הראשיות הן בעלות מתח נמוך, סוללה מקוצרת או מוארקת עלולה להפיק זרם מספיק לגרימת כוויות או להצתת חומרים דליקים.

Sebbene le batterie di alimentazione siano a basso voltaggio, una batteria in corto circuito o a massa può fornire corrente sufficiente da bruciare materiali combustibili o provocare ustioni ai tecnici di manutenzione.

メイン・バッテリーの電圧は低くても、ショートしたり、接地したバッテリーが、作業者にやけどを負わせたり、可燃物を燃やすだけの電流を発生させる場合があります。

Aunque las baterías principales tienen un voltaje bajo, una batería cortocircuitada o con contacto a tierra puede producir la corriente suficiente como para quemar material combustible o provocar quemaduras en el personal.

Safety notice 8

⚠ DANGER

Before removing any FRU, turn off the computer, unplug all power cords from electrical outlets, remove the battery pack, and then disconnect any interconnecting cables.

Avant de retirer une unité remplaçable en clientèle, mettez le système hors tension, débranchez tous les cordons d'alimentation des socles de prise de courant, retirez la batterie et déconnectez tous les cordons d'interface.

Die Stromzufuhr muß abgeschaltet, alle Stromkabel aus der Steckdose gezogen, der Akku entfernt und alle Verbindungskabel abgenommen sein, bevor eine FRU entfernt wird.

לפני סילוק FRU כלשהו, יש לכבות את המחשב,
לנתק את כל כבלי החשמל משקעי החשמל, להוציא
את סוללת הסוללה, ואז לנתק כבלי חיבור אחרים
אם יש כאלה.

Prima di rimuovere qualsiasi FRU, spegnere il sistema, scollegare dalle prese elettriche tutti i cavi di alimentazione, rimuovere la batteria e poi scollegare i cavi di interconnessione.

FRUを取り外す前に、ThinkPadの電源を切って、すべての電源コードをコンセントから外してください。次に、バッテリー・パックを外し、相互接続ケーブルを外してください。

Antes de quitar una FRU, apague el sistema, desenchufe todos los cables de las tomas de corriente eléctrica, quite la batería y, a continuación, desconecte cualquier cable de conexión entre dispositivos.

Laser compliance statement

Some models of Lenovo computer are equipped from the factory with an optical storage device such as a CD-ROM drive or a DVD-ROM drive. Such devices are also sold separately as options. If one of these drives is installed, it is certified in the U.S. to conform to the requirements of the Department of Health and Human Services 21 Code of Federal Regulations (DHHS 21 CFR) Subchapter J for Class 1 laser products. Elsewhere, the drive is certified to conform to the requirements of the International Electrotechnical Commission (IEC) 825 and CENELEC EN 60 825 for Class 1 laser products.

If a CD-ROM drive, a DVD-ROM drive, or another laser device is installed, note the following:

CAUTION

Use of controls or adjustments or performance of procedures other than those specified herein might result in hazardous radiation exposure.

O uso de controles, ajustes ou desempenho de procedimentos diferentes daqueles aqui especificados pode resultar em perigosa exposição à radiação.

凡未在这里指明的任何控制用法、调整、行为，都会导致严重后果。

Pour éviter tout risque d'exposition au rayon laser, respectez les consignes de réglage et d'utilisation des commandes, ainsi que les procédures décrites.

Werden Steuer- und Einstellelemente anders als hier festgesetzt verwendet, kann gefährliche Laserstrahlung auftreten.

Az itt előírt eljárásoktól, beállításoktól és vezérlésektől eltérni a lézersugárzás veszélye miatt kockázatos!

L'utilizzo di controlli, regolazioni o l'esecuzione di procedure diverse da quelle specificate possono provocare l'esposizione a.

Использование элементов настройки и выполнение процедур иных, чем указано здесь, может привести к опасному радиационному облучению.

Použitie kontrol, úprav alebo iných vykonaní od iných výrobcov, ako je v tomto špecifikované, mohlo by mať za následok nebezpečenstvo vystavenia sa vyžiarovaniu.

本書で指定された内容以外の、お客様による整備、調整、または手順を行った場合、レーザー光の放射の危険があります。

El uso de controles o ajustes o la ejecución de procedimientos distintos de los aquí especificados puede provocar la exposición a radiaciones peligrosas.

Opening the CD-ROM drive, the DVD-ROM drive, or any other optical storage device could result in exposure to hazardous laser radiation. There are no serviceable parts inside those drives. **Do not open.**

A CD-ROM drive, a DVD-ROM drive, or any other storage device installed may contain an embedded Class 3A or Class 3B laser diode. Note the following:

 **DANGER**

Emits visible and invisible laser radiation when open. Do not stare into the beam, do not view directly with optical instruments, and avoid direct exposure to the beam.

Radiação por raio laser ao abrir. Não olhe fixo no feixe de luz, não olhe diretamente por meio de instrumentos óticos e evite exposição direta com o feixe de luz.

开启时会有激光发射时，请勿直视激光光束，请勿直接查看视觉仪器，并且避免直接接触在激光光束之中。

Rayonnement laser si carter ouvert. Évitez de fixer le faisceau, de le regarder directement avec des instruments optiques, ou de vous exposer au rayon.

Laserstrahlung bei geöffnetem Gerät. Nicht direkt oder über optische Instrumente in den Laserstrahl sehen und den Strahlungsbereich meiden.

Kinyitáskor lézersugár! Ne nézzen bele se szabad szemmel, se optikai eszközökkel. Kerülje a sugárnyalábbal való érintkezést!

Aprenndo l'unità vengono emesse radiazioni laser. Non fissare il fascio, non guardarlo direttamente con strumenti ottici e evitare l'esposizione diretta al fascio.

Открывая, берегитесь лазерного излучения. Не смотрите на луч, не разглядывайте его с помощью оптических инструментов, а также избегайте прямого воздействия лазерного луча.

Keď je laserová jednotka otvorená. Vyhňte sa priamemu pohľadu a nehládte priamo s optickými nástrojmi do lúča a vyhňte sa priamemu vystaveniu lúčov.

開けるとレーザー光が放射されます。光線を見つめたり、光学機械を使って直接見たりしないでください。

Radiación láser al abrir. No mire fijamente ni examine con instrumental óptico el haz de luz. Evite la exposición directa al haz.

Important service information

This chapter presents the following important service information:

- “Strategy for replacing FRUs” on page 16
 - “Strategy for replacing a hard disk drive” on page 17
 - “Important notice for replacing a system board” on page 17
- “Important information about replacing RoHS compliant FRUs” on page 18

Important:

BIOS and device driver fixes are customer-installable. The BIOS and device drivers are posted on the customer support site:
<http://support.lenovo.com>.

Strategy for replacing FRUs

Before replacing parts:

Make sure that all software fixes, drivers, and BIOS downloads are installed before replacing any FRUs listed in this manual.

After a system board is replaced, ensure that the latest BIOS is loaded to the system board before completing the service action.

To download software fixes, drivers, and BIOS, follow the steps below:

1. Go to <http://support.lenovo.com>.
2. Enter the serial number or select a product or use Lenovo smart downloading.
3. Select the BIOS/Driver/Applications and download.
4. Follow the directions on the screen and install the necessary software.

Use the following strategy to prevent unnecessary expense for replacing and servicing FRUs:

- If you are instructed to replace an FRU, but the replacement does not solve the problem, reinstall the original FRU before you continue.
- Some computers have both a processor board and a system board. If you are instructed to replace either of them, and replacing one of them does not solve the problem, reinstall that board, and then replace the other one.
- If an adapter or a device consists of more than one FRU, any of the FRUs may be the cause of the error. Before replacing the adapter or device, remove the FRUs one by one to see if the symptoms change. Replace only the FRU that changed the symptoms.

Attention: The setup configuration on the computer you are servicing may have been customized. Running Automatic Configuration may alter the settings. Note the current configuration settings (using the View Configuration option); then, when service has been completed, verify that those settings remain in effect.

Strategy for replacing a hard disk drive

Always try to run a low-level format before replacing a hard disk drive. This will cause all customer data on the hard disk to be lost. Make sure that the customer has a current backup of the data before performing this action.

Attention: The drive startup sequence in the computer you are servicing may have been changed. Be extremely careful during write operations such as copying, saving, or formatting. If you select an incorrect drive, data or programs can be overwritten.

Important notice for replacing a system board

Some components mounted on a system board are very sensitive. Improper handling can cause damage to those components, and may cause a system malfunction.

Attention: When handling a system board:

- Do not drop the system board or apply any excessive force to it.
- Avoid rough handling of any kind.
- Avoid bending the system board and hard pushing to prevent cracking at each BGA (Ball Grid Array) chipset.

Important information about replacing RoHS compliant FRUs

RoHS, The Restriction of Hazardous Substances in Electrical and Electronic Equipment Directive (2002/95/EC) is a European Union legal requirement affecting the global electronics industry. RoHS requirements must be implemented on Lenovo products placed on the market after June 2006. Products on the market before June 2006 are not required to have RoHS compliant parts. If the original FRU parts are non-compliant, replacement parts can also be non-compliant. In all cases if the original FRU parts are RoHS compliant, the replacement part must also be RoHS compliant.

Note: RoHS and non-RoHS FRU part numbers with the same fit and function are identified with unique FRU part numbers.

Lenovo plans to transit to RoHS compliance well before the implementation date and expects its suppliers to be ready to support Lenovo's requirements and schedule in the EU. Products sold in 2005 and 2006 will contain some RoHS compliant FRUs. The following statement pertains to these products and any product Lenovo produces containing RoHS compliant FRUs.

RoHS compliant FRUs have unique FRU part numbers. Before or after the RoHS implementation date, failed RoHS compliant parts must always be replaced with RoHS compliant ones, so only the FRUs identified as compliant in the system HMM or direct substitutions for those FRUs may be used.

Products marketed before June 2006		Products marketed after June 2006	
Current or original part	Replacement FRU	Current or original part	Replacement FRU
Non-RoHS	Can be Non-RoHS	Must be RoHS	Must be RoHS
Non-RoHS	Can be RoHS		
Non-RoHS	Can sub to RoHS		
RoHS	Must be RoHS		

Note: A direct substitution is a part with a different FRU part number that is automatically shipped by the distribution center at the time of the order.

General checkout

This chapter presents the following information:

- “What to do first” on page 20
- “Power system checkout” on page 21

Before you go to the checkout, make sure to read the following important notes:

Important notes:

- **Only certified trained personnel can service the computer.**
- **Before replacing any FRU, read the entire page on removing and replacing FRUs.**
- **When you replace FRUs, use new nylon-coated screws.**
- **Be extremely careful during such write operations as copying, saving, or formatting.** Drives in the computer that you are servicing sequence might have been altered. If you select an incorrect drive, data or programs might be overwritten.
- **Replace an FRU only with another FRU of the correct model.** When you replace an FRU, make sure that the machine model and the FRU part number are correct by referring to the FRU parts list.
- **An FRU should not be replaced just because of a single, unreproducible failure.** Single failures can occur for a variety of reasons that have nothing to do with a hardware defect, such as cosmic radiation, electrostatic discharge, or software errors. Consider replacing an FRU only when a problem recurs. If you suspect that an FRU is defective, clear the error logs and run the test again. If the error does not recur, do not replace the FRU.
- **Be careful not to replace a nondefective FRU.**

What to do first

When you do return an FRU, you must include the following information in the parts exchange form or parts return form that you attach to it:

1. Name and phone number of servicer
2. Date of service
3. Date on which the machine failed
4. Date of purchase
5. Procedure index and page number in which the failing FRU was detected
6. Failing FRU name and part number
7. Machine type, model number, and serial number
8. Customer's name and address

Note for warranty: During the warranty period, the customer may be responsible for repair costs if the computer damage was caused by misuse, accident, modification, unsuitable physical or operating environment, or improper maintenance by the customer.

The following is a list of some common items that are not covered under warranty and some symptoms that might indicate that the system was subjected to stress beyond normal use.

Before checking problems with the computer, determine whether the damage is covered under the warranty by referring to the following list:

The following are not covered under warranty:

- LCD panel cracked from the application of excessive force or from being dropped
- Scratched (cosmetic) parts
- Distortion, deformation, or discoloration of the cosmetic parts
- Plastic parts, latches, pins, or connectors that have been cracked or broken by excessive force
- Damage caused by liquid spilled into the system
- Damage caused by the improper insertion of a PC Card or the installation of an incompatible card
- Improper disk insertion or use of an optical drive
- Diskette drive damage caused by pressure on the diskette drive cover, foreign material in the drive, or the insertion of a diskette with multiple labels
- Damaged or bent diskette eject button
- Fuses blown by attachment of a nonsupported device
- Forgotten computer password (making the computer unusable)
- Sticky keys caused by spilling a liquid onto the keyboard
- Use of an incorrect AC adapter on laptop products

The following symptoms might indicate damage caused by nonwarranted activities:

- Missing parts might be a symptom of unauthorized service or modification.
- If the spindle of a hard disk drive becomes noisy, it may have been subjected to excessive force, or dropped.

Power system checkout

To verify a symptom, follow the steps below:

1. Turn off the computer.
2. Remove the battery pack.
3. Connect the AC adapter.
4. Make sure that power is supplied when you turn on the computer.
5. Turn off the computer.
6. Disconnect the AC adapter and install the charged battery pack.
7. Make sure that the battery pack supplies power when you turn on the computer.

If you suspect a power problem, see the appropriate one of the following power supply checkouts:

- “Checking the AC adapter” on page 21
- “Checking operational charging” on page 22
- “Checking the battery pack” on page 22

Checking the AC adapter

You are here because the computer fails only when the AC adapter is used.

- If the power-on indicator does not turn on, check the power cord of the AC adapter for correct continuity and installation.
- If the computer does not charge during operation, go to “Checking operational charging”.

To check the AC adapter, follow the steps below:

1. Unplug the AC adapter cable from the computer.
2. Measure the output voltage at the plug of the AC adapter cable. See the following figure:

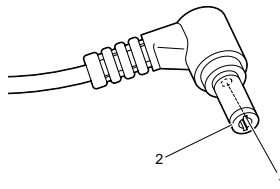

Pin	Voltage (V DC)
1	+20
2	0

Note: Output voltage for the AC adapter pin No. 2 may differ from the one you are servicing.

3. If the voltage is not correct, replace the AC adapter.
4. If the voltage is acceptable, do the following:
 - Replace the system board.
 - If the problem persists, go to “Lenovo ideapad 310-14ISK/ideapad 310-15ISK/ideapad 310 Touch-15ISK/ideapad 310-15ABR” on page 27.

Note: Noise from the AC adapter does not always indicate a defect.

Checking operational charging

To check whether the battery charges properly during operation, use a discharged battery pack or a battery pack that has less than 50% of the total power remaining when installed in the computer.

Perform operational charging. If the battery status indicator or icon does not light on, remove the battery pack and let it return to room temperature. Reinstall the battery pack. If the charge indicator or icon is still off, replace the battery pack.

If the charge indicator still does not light on, replace the system board. Then reinstall the battery pack. If it is still not charged, go to the next section.

Checking the battery pack

Battery charging does not start until the Power Meter shows that less than 95% of the total power remains; under this condition the battery pack can charge to 100% of its capacity. This protects the battery pack from being overcharged or from having a shortened life.

To check your battery, move your cursor to the Power Meter icon in the icon tray of the Windows® taskbar and wait for a moment (but do not click it), and the percentage of battery power remaining is displayed. To get detailed information about the battery, double-click the Power Meter icon.

Note: If the battery pack becomes hot, it may not be able to be charged. Remove it from the computer and leave it at room temperature for a while. After it cools down, reinstall and recharge it.

Related service information

This chapter presents the following information:

- “Restoring the factory contents by using Recovery Disc Set” on page 23
- “Passwords” on page 24
- “Power management” on page 25

Restoring the factory contents by using Recovery Disc Set

When the hard disk drive or solid state drive is replaced because of a failure, no product recovery program is on the new drive. In this case, you must use the *Recovery Disc Set* for the computer. Order the *Recovery Disc Set* and the drive at the same time so that you can recover the new drive with the pre-installed software when they arrive.

The *Recovery Disc Set* consists of the following set of DVDs to restore the computer to the original factory configuration.

Start Recovery Disc (one disc)

This disc is used to format the hard disk drive and initiate the recovery process.

Operating System Recovery Disc (one or more discs)

This disc restores the Microsoft Windows operating system.

Applications and Drivers Recovery Disc (one or more discs)

This disc restores the pre-installed applications and drivers on the computer.

Supplemental Recovery Disc

This disc contains additional content, such as software for specific models and updates to the software that was preloaded on the computer. Not all recovery disc sets come with a *Supplemental Recovery Disc*.

To restore the computer to the original factory configuration using the recovery disc set, do the following:

1. Insert the bootable *Start Recovery Disc* into the optical drive.
2. Start the computer. When the Lenovo logo comes up, immediately press F12; on the boot sequence menu, select the optical drive as the first boot-up device. The computer will boot from the *Start Recovery Disc*. Follow the on-screen instructions to begin the recovery process.
3. Read the license. If you agree with the terms, select **I accept these terms and conditions** and then click **Next**.
4. Insert the **Operating System Recovery Disc** when prompted and click **Yes** to begin the operating system recovery process.
5. Insert the *Applications and Drivers Recovery Disc* when prompted and then click **OK** to begin the applications and drivers recovery process.
6. If you have a *Supplemental Recovery Disc*, insert it when prompted and click **Yes**. If you do not have a *Supplemental Recovery Disc*, click **No**.

7. When all of the data has been copied from the last disc in the set, remove the disc and restart the computer.

Note: The remainder of the recovery process is fully automated and no action is required by you. The computer will restart into the Windows desktop several times and you might experience periods when no activity is apparent on the screen for several minutes at a time. This is normal.

8. When the recovery process is complete, the Welcome to the Microsoft Windows screen is displayed. Follow the instructions on the screen to complete the Windows setup.

Passwords

As many as three passwords may be needed for any Lenovo computer: the power-on password (POP), the hard disk password (HDP), and the supervisor password (SVP).

If any of these passwords has been set, a prompt for it appears on the screen whenever the computer is turned on. The computer does not start until the password is entered.

Exception: If only an SVP is installed, the password prompt does not appear when the operating system is booted.

Power-on password

A power-on password (POP) protects the system from being powered on by an unauthorized person. The password must be entered before an operating system can be booted.

Hard-disk password

There are two hard-disk passwords (HDPs):

+ User HDP - for the user

+ Master HDP - for the system administrator, who can use it to get access to the hard disk drive even if the user has changed the user HDP

Attention: If the user HDP has been forgotten, check whether a master HDP has been set. If it has, it can be used for access to the hard disk drive. If no master HDP is available, neither Lenovo nor Lenovo authorized service technicians provide any services to reset either the user or the master HDP, or to recover data from the hard disk drive. The hard disk drive can be replaced for a scheduled fee.

Supervisor password

A supervisor password (SVP) protects the system information stored in the BIOS Setup Utility. The user must enter the SVP in order to get access to the BIOS Setup Utility and change the system configuration.

Attention: If the SVP has been forgotten and cannot be made available to the servicer, there is no service procedure to reset the password. The system board must be replaced for a scheduled fee.

Power management

Note: Power management modes are not supported for APM operating system.

To reduce power consumption, the computer has three power management modes: screen blank, sleep (standby), and hibernation.

Screen blank state

If the time set on the “Turn off monitor” timer in the operating system expires, the LCD backlight turns off. You can also turn off the LCD backlight by pressing



To end screen blank state and resume normal operation, press .

Putting your computer to sleep

If you will be away from your computer for only a short time, put the computer to sleep.

When the computer is in sleep mode, you can quickly wake it to resume use, bypassing the startup process.

To put the computer to sleep, do one of the following:

- Close the display lid.
- Press the power button.
- Select the Start button, then select **Power**  → **Sleep**.

Note: Put your computer to sleep before you move it. Moving your computer while the hard disk drive is spinning can damage the hard disk, causing loss of data.

To wake the computer, do one of the following:

- Press any key on the keyboard.
- Press the power button.

Shutting down the computer

If you are not going to use your computer for a long time, shut it down.

To shut down your computer, do one of the following:

- Select the Start button, then select **Power**  → **Shut down**.



- Right-click or press the Start button in the lower-left corner and select **Shut down** or **sign out** → **Shut down**.

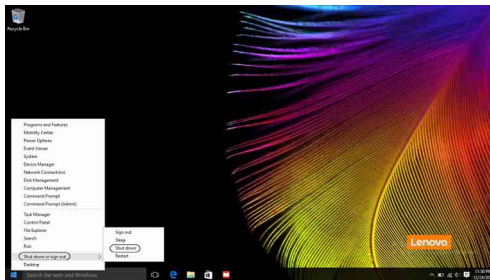

Lenovo ideapad 310-14ISK/ideapad 310-15ISK/ ideapad 310 Touch-15ISK/ideapad 310-15ABR

This chapter presents the following product-specific service references and product-specific parts information:

- “Specifications” on page 27
- “Status indicators” on page 30
- “Hotkeys” on page 32
- “FRU replacement notices” on page 33
- “Removing and replacing an FRU” on page 34
- “Locations” on page 68
- “Parts list” on page 72

Specifications

The following table lists the specifications of the Lenovo ideapad 310-14ISK/ideapad 310-15ISK/ideapad 310 Touch-15ISK/ideapad 310-15ABR:

Table 1. Specifications

	ideapad 310-14ISK	ideapad 310-15ISK/ ideapad 310 Touch-15ISK/ ideapad 310-15ABR
Form Factor		
Dimensions	Appr. 341.8 mm × 249.9 mm × 22.7 mm	Appr. 379 mm × 260 mm × 22.9 mm
Weight	Appr. 2.1 kg with battery	Appr. 2.2 kg with battery
LCD size	14.0-inch	15.6-inch
Processor		
See the system properties of your computer, you can do this as follows: Click Control Panel , then click Hardware and Sound , click Device Manager under Devices and Printers and double click Processors .		
Memory		
Type and speed	DDR4-2133 MHz	
Maximum supported capacity	8 GB	
Slots	SODIMM × 1, on board × 1	

// *Lenovo ideapad 310-14ISK/ideapad 310-15ISK/ideapad 310 Touch-15ISK/ideapad 310-15ABR Hardware Maintenance Manual*

Hard disk drive	
Form factor	2.5-inch, 9.5/7 mm
Capacity	HDD: 500 GB/1 TB SSHD: 500 GB+8 GB/1 TB+8 GB SSD: 128 GB/256 GB
Interface	SATA 3
Optical drive	
Form factor	9.0 mm
Type	RAMBO
Display	
Display resolution (LCD)	16:9 (1,366 × 768/1,920 × 1,080 pixels)
LCD backlight	LED
I/O Ports	
USB	USB 3.0 × 1, USB 2.0 × 2
Audio	Combo audio jack × 1
Communication	RJ-45 × 1
Video/Audio	HDMI slot × 1
Memory card slot	4 in 1 slot × 1 (SD/SDHC/SDXC/MMC)
Battery pack	
Type	Li-ion battery pack
Cells/Capacity	2 Cells, 30/39 Wh
Note: The capacity given here is the typical or average capacity as measured in a specific test environment. Capacities measured in other environments may differ but are no lower than the rated capacity (see product label).	
AC power adapter	
Input	100-240 V, 50-60 Hz
Output voltage	20 V DC
Power	45/65 W
Miscellaneous	
Camera	0.3 M/HD
Security	Kensington slot × 1

Bus architecture	
	2133MHz DDR4
	PCIE
	SATA
	USB
	LPC
	HDA
	EDP
	DP
	HDMI
	SPI
CMOS RAM	
	Embedded in PCH

Status indicators

The system status indicators below show the computer status:

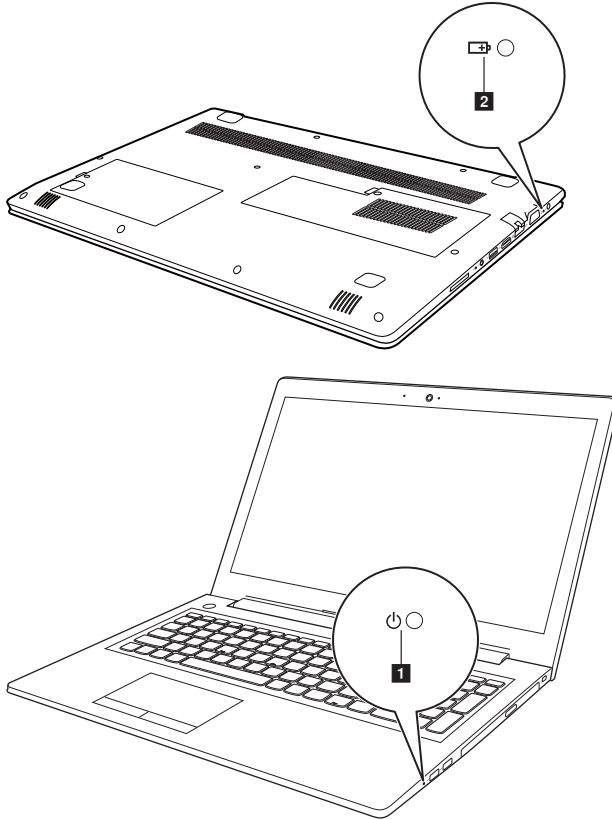



Table 2. Status indicators













Battery/Charging status indicator 		
AC power adapter status	Indicator status	Meaning
Disconnected	Off	The computer is in sleep mode or turned off; The battery has more than 20% charge.
	Solid amber	The battery has between 5% and 20% charge.
	Fast blinking amber	The battery has between 1% and 5% charge.
Connected	Slow blinking amber	The battery is being charged. When battery charge reaches 20%, the blinking color changes to white.
	Slow blinking white	The battery has between 20% and 80% charge and is still charging. When the battery reaches 80% charge the light will stop blinking.
	Solid white	The battery has more than 80% charge, charging will continue until the battery is fully charged.
Power status indicator 		
Indicator	Indicator status	Meaning
Power status indicator	On (solid white)	The computer is powered on.
	Blinking	The computer is in sleep mode.
	Off	The computer is powered off.

Hotkeys

The hotkeys are located in the function key row of the keyboard. By pressing the appropriate hotkey, you can change system settings instantly.

The following describes the function of each hotkey.

Table 3. Hotkeys

 : Mutes/unmutes the sound.	 : Enables/disables airplane mode.
 : Decreases the volume level.	 : Enables/disables camera.
 : Increases the volume level.	 : Locks/unlocks the LCD screen.
 : Enables/disables microphone.	 : Enables the external projector or dangles the external display.
 : Refreshes page.	 : Decreases display brightness.
 : Enables/disables the touch pad.	 : Increases display brightness.

FRU replacement notices

This section presents notices related to removing and replacing parts. Read this section carefully before replacing any FRU.

Screw notices

Loose screws can cause a reliability problem. In the Lenovo computer, this problem is addressed with special nylon-coated screws that have the following characteristics:

- They maintain tight connections.
- They do not easily come loose, even with shock or vibration.
- They are harder to tighten.
- Each one should be used only once.

Do the following when you service this machine:

- Keep the screw kit in your tool bag.
- Remove screws carefully for reuse.
- Use a torque screwdriver if you have one.

Tighten screws as follows:

- **Plastic to plastic**

Turn an additional 90° after the screw head touches the surface of the plastic part:

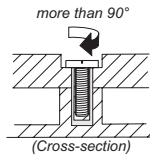

- **Logic card to plastic**

Turn an additional 180° after the screw head touches the surface of the logic card:

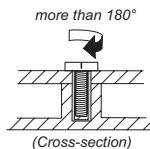

- **Torque driver**

If you have a torque screwdriver, refer to the "Torque" column for each step.

- Make sure that you use the correct screws. If you have a torque screwdriver, tighten all screws firmly to the torque shown in the table. **Never use a screw that you removed. Use a new one. Make sure that all screws are tightened firmly.**
- Ensure torque screwdrivers are calibrated correctly following country specifications.

Removing and replacing an FRU

This section presents exploded figures with the instructions to indicate how to remove and replace the FRU. Make sure to observe the following general rules:

1. Do not attempt to service any computer unless you have been trained and certified. An untrained person runs the risk of damaging parts.
2. Before replacing any FRU, review “FRU replacement notices” on page 33.
3. Begin by removing any FRUs that have to be removed before the failing FRU. Any of such FRUs are listed at the top of the page. Remove them in the order in which they are listed.
4. Follow the correct sequence in the steps to remove the FRU, as given in the figures by the numbers in square callouts.
5. When turning a screw to replace an FRU, turn it in the direction as given by the arrow in the figure.
6. When removing the FRU, move it in the direction as given by the arrow in the figure.
7. To put the new FRU in place, reverse the removal procedures and follow any of the notes that pertain to replacement. For information about connecting and arranging internal cables, see “Locations” on page 68.
8. When replacing an FRU, use the correct screw as shown in the procedures.

 **DANGER**

Before removing any FRU, turn off the computer, unplug all power cords from electrical outlets, remove the battery pack, and then disconnect any of the interconnecting cables.

Attention: After replacing an FRU, do not turn on the computer until you have made sure that all screws, springs, and other small parts are in place and none are loose inside the computer. Verify this by shaking the computer gently and listening for rattling sounds. Metallic parts or metal flakes can cause electrical short circuits.

Attention: The system board is sensitive to, and can be damaged by, electrostatic discharge. Before touching it, establish personal grounding by touching a ground point with one hand or using an electrostatic discharge (ESD) strap (P/N 6405959) to remove potential shock reasons.

Note: The illustrations used in this section are of the Lenovo ideapad 310-15ISK, unless otherwise stated.

1010 Hard disk drive(HDD) slot compartment cover

Figure 1. Removal steps of HDD slot compartment cover

Remove the screw **1** that secure the compartment cover. Remove the compartment cover **2** .

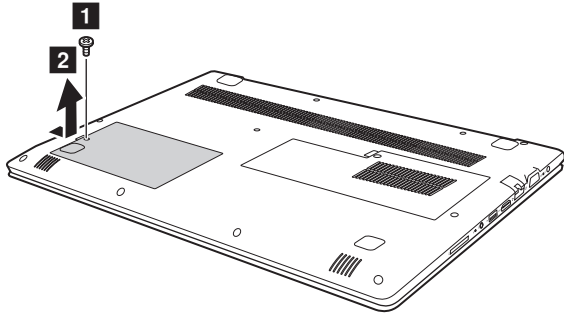

Step	Screw (quantity)	Color	Torque
1	M2.5 × 6 mm, flat-head, nylok-coated (1)	Black	3.0±0.3 kgfcm

1020 Hard disk drive

For access, remove this FRU:

- “1010 Hard disk drive(HDD) slot compartment cover” on page 35

Attention:

- **Do not drop the hard disk drive or apply any physical shock to it.**
The hard disk drive is sensitive to physical shock. Improper handling can cause damages and permanent loss of data.
- Before removing the drive, suggest the customer to backup all the information on it if possible.
- Never remove the drive while the system is operating or is in suspend mode.

Figure 2. Removal steps of hard disk drive

ideapad 310-14ISK: Remove the frame fixing screws 1.

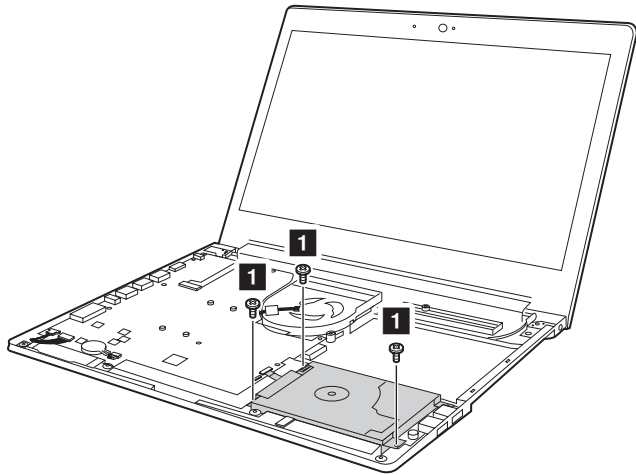

Step	Screw (quantity)	Color	Torque
1	M2 × 6 mm, flat-head, nylok-coated (3) (ideapad 310-14ISK)	Black	1.85+/-0.15 kgfcm

Figure 2. Removal steps of hard disk drive (continued)

ideapad 310-14ISK: Detach the hard disk drive connector shown by arrows **2** and **3**.

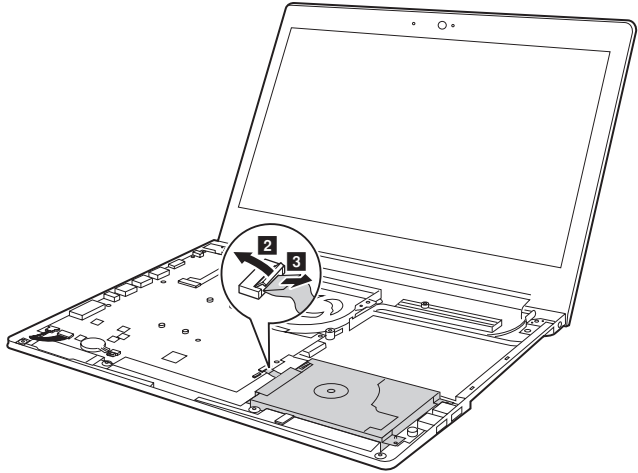

Take out the hard disk drive secured in a metal frame in the direction shown by arrow **4**.

ideapad 310-15ISK/ideapad 310 Touch-15ISK/ideapad 310-15ABR:

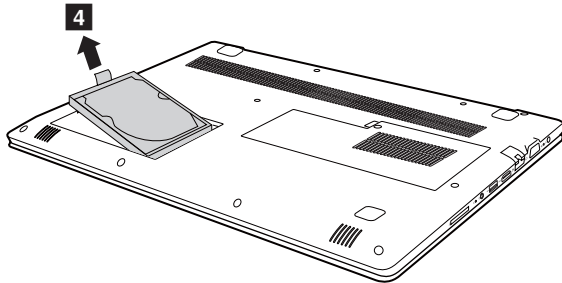
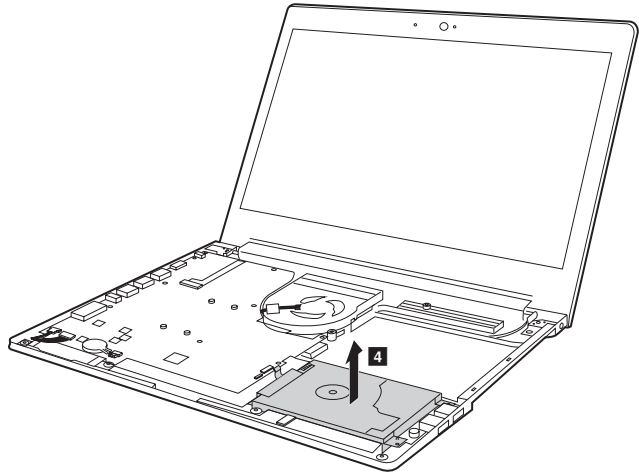
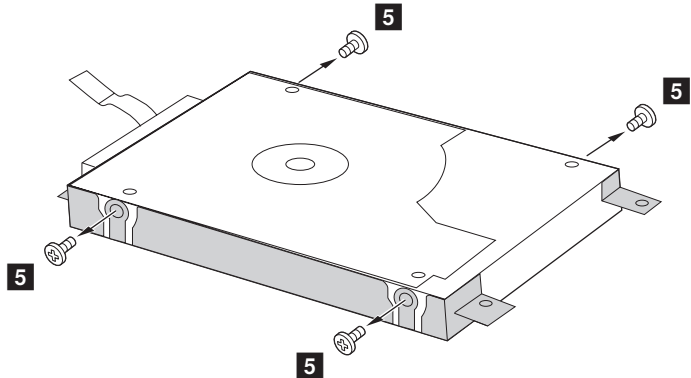

Figure 2. Removal steps of hard disk drive (continued)

ideapad 310-14ISK:



Remove the hard disk drive by gently pulling it in the direction of the arrow **5**. Take out the hard disk drive secured in a metal frame.



Step	Screw (quantity)	Color	Torque	PN
4	M3.0 × 3 mm, flat-head, nylok-coated (4)	Silver	3.0±0.3 kgfcm	90203986

When installing: Make sure that the HDD connector is attached firmly.

1030 Memory/Mini PCI Express Card slot compartment cover and DIMM

For access, remove these FRUs in order

- “1010 Hard disk drive(HDD) slot compartment cover” on page 35
- “1020 Hard disk drive” on page 36

Figure 3. Removal steps of Memory/Mini PCI Express Card slot compartment cover and DIMM

Remove the screw that secure the compartment cover **1**. Remove the compartment cover **2**.

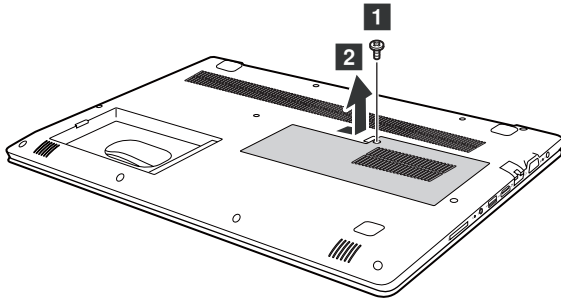

Step	Screw (quantity)	Color	Torque
1	M2.5 × 6 mm, flat-head, nylok-coated (1)	Black	3.0±0.3 kgfcm

Figure 3. Removal steps of Memory/Mini PCI Express Card slot compartment cover and DIMM (continued)

Release the two latches on both edges of the socket at the same time in the direction shown by arrows **3**, and then unplug the DIMM in the direction shown by arrow **4**.

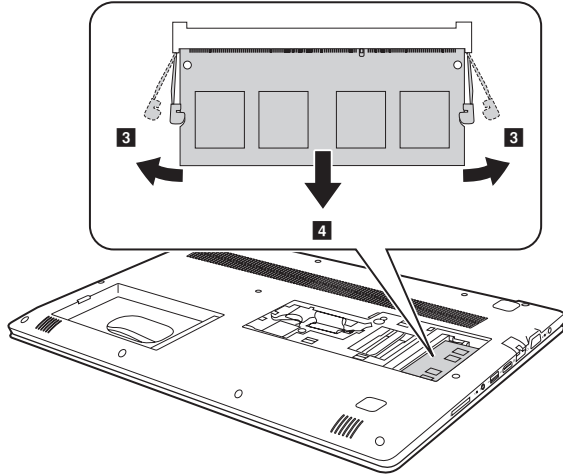

When installing: Insert the notched end of the DIMM into the socket. Push the DIMM firmly, and pivot it until it snaps into the place. Make sure that it is firmly fixed in the slot and difficult to be moved.

1040 PCI Express Mini Card for wireless LAN/WAN

For access, remove these FRUs in order

- “1010 Hard disk drive(HDD) slot compartment cover” on page 35
- “1020 Hard disk drive” on page 36
- “1030 Memory/Mini PCI Express Card slot compartment cover and DIMM” on page 39

Important:

- The preinstalled WLAN module may only be replaced with a Lenovo approved module in order to comply with FCC and IC regulations. Refer to “Overall” on page 73 for Lenovo part numbers for the approved modules.

Figure 4. Removal steps of PCI Express Mini Card for wireless LAN/WAN

Disconnect the two wireless LAN cables (black, white) **1**, and then remove the screw **2**.

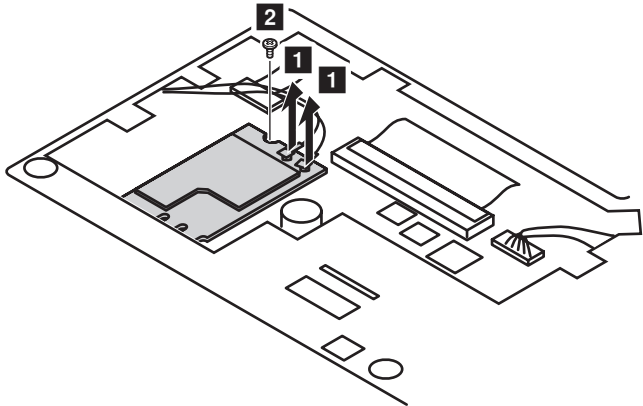

In step **1**, unplug the jacks by using the removal tool antenna RF connector (P/N: 08K7159), or pick up the connectors with your fingers and gently unplug them in the direction shown by arrows.

Figure 4. Removal steps of PCI Express Mini Card for wireless LAN/WAN (continued)

Notes: wireless LAN card has 2 cables in step **1**.

wireless LAN card in some models may have 3 cables in step **1**.

Step	Screw (quantity)	Color	Torque	PN
2	M2 × 3.0 mm, flat-head, nylok-coated (1)	Silver	1.85±0.15 kgfcm	90001118

Remove the card in the direction shown by arrow **3**.

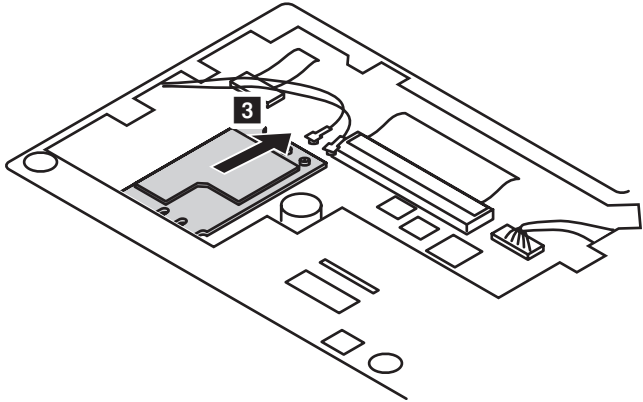

When installing:

- In models with a wireless LAN card that has two antenna connectors, plug the black cable (1st) (MAIN) into the jack labeled **1**, and the white cable (2nd) (AUX) into jack labeled **2** on the card.
- In models with a wireless LAN card that has three antenna connectors, plug the black cable (1st) (MAIN) into the jack labeled **1**, the grey cable (3rd) into jack labeled **3**, and the white cable (2nd) (AUX) into jack labeled **2** on the card.

1050 Optical drive

For access, remove these FRUs in order:

- “1010 Hard disk drive(HDD) slot compartment cover” on page 35
- “1020 Hard disk drive” on page 36
- “1030 Memory/Mini PCI Express Card slot compartment cover and DIMM” on page 39
- “1040 PCI Express Mini Card for wireless LAN/WAN” on page 41

Figure 5. Removal steps of optical drive

Remove the screw **1**, Pull the optical drive out in the direction shown by arrow **2**.

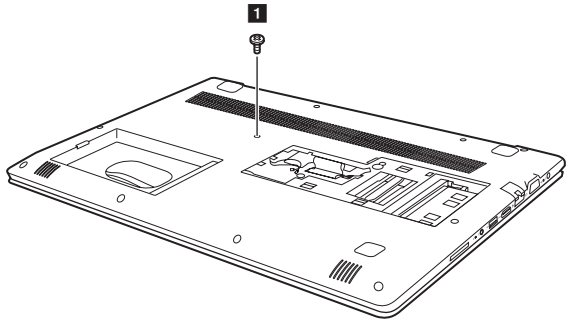

Step	Screw (quantity)	Color	Torque	PN
1	M2.5 × 6 mm, flat-head, nylokcoated (1)	Black	3+/-0.3 kgfcm	90205118

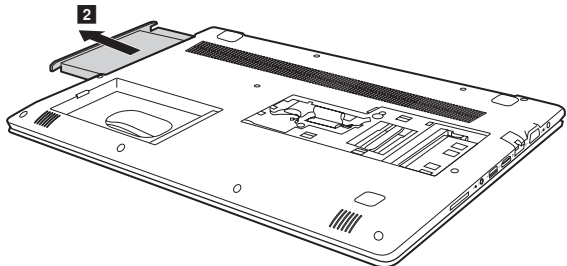

1060 Keyboard bezel

For access, remove these FRUs in order:

- “1010 Hard disk drive(HDD) slot compartment cover” on page 35
- “1020 Hard disk drive” on page 36
- “1030 Memory/Mini PCI Express Card slot compartment cover and DIMM” on page 39
- “1040 PCI Express Mini Card for wireless LAN/WAN” on page 41
- “1050 Optical drive” on page 43

Figure 6. Removal steps of keyboard bezel

Remove screws **1**.

ideapad 310-15ISK/ideapad 310 Touch-15ISK/ideapad 310-15ABR:

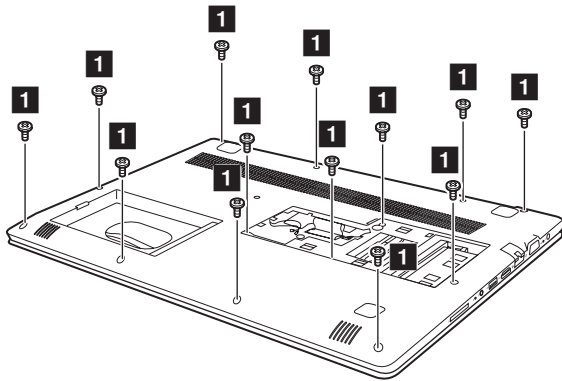

Step	Screw (quantity)	Color	Torque	PN
1	M2.5 x 6 mm, flat-head, nylok-coated (11)	Black	3±0.3 kgf.cm	90205118
	M2 x 6 mm, flat-head, nylok-coated (3)	Black	1.85±0.15 kgf.cm	

Figure 6. Removal steps of keyboard bezel (continued)

Pull the touch pad connector and keyboard connector slot cover upward as shown by arrow **2**, and detach the touch pad board cable and keyboard cable from the touch pad board connector and keyboard connector in the direction shown by arrow **3**.

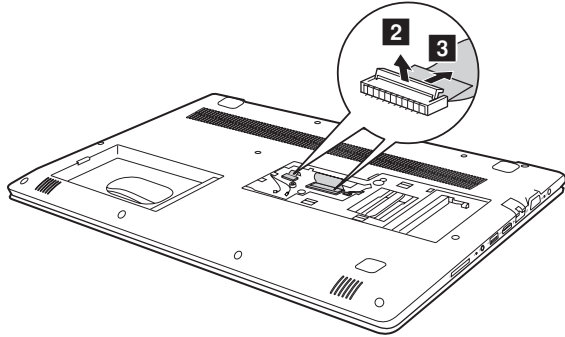

When installing: Make sure that the FPC connectors are attached firmly. Remove the keyboard bezel in the direction shown by arrow **4**.

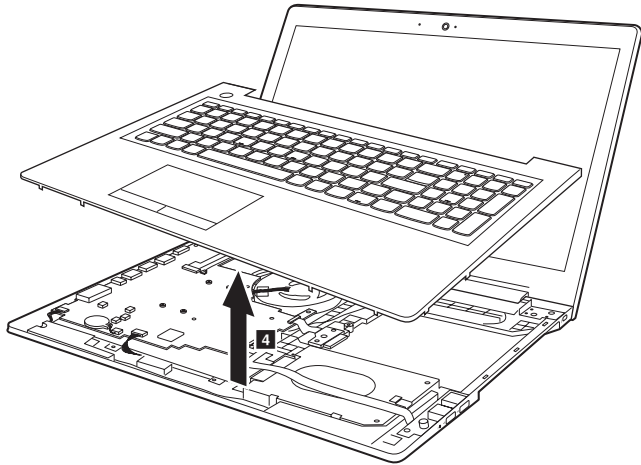

1070 System board

Important notices for handling the system board:

When handling the system board, bear the following in mind.

- Be careful not to drop the system board on a bench top that has a hard surface, such as metal, wood, or composite.
- Avoid rough handling of any kind.
- In the whole process, make sure not to drop or stack the system board.
- If you put a system board down, make sure to put it only on a padded surface such as an ESD mat or conductive corrugated material.

For access, remove these FRUs in order:

- “1010 Hard disk drive(HDD) slot compartment cover” on page 35
- “1020 Hard disk drive” on page 36
- “1030 Memory/Mini PCI Express Card slot compartment cover and DIMM” on page 39
- “1040 PCI Express Mini Card for wireless LAN/WAN” on page 41
- “1050 Optical drive” on page 43
- “1060 Keyboard bezel” on page 44

Figure 7. Removal steps of system board

Remove screws **1** and screw **2**.

ideapad 310-15ISK/ideapad 310 Touch-15ISK/ideapad 310-15ABR:

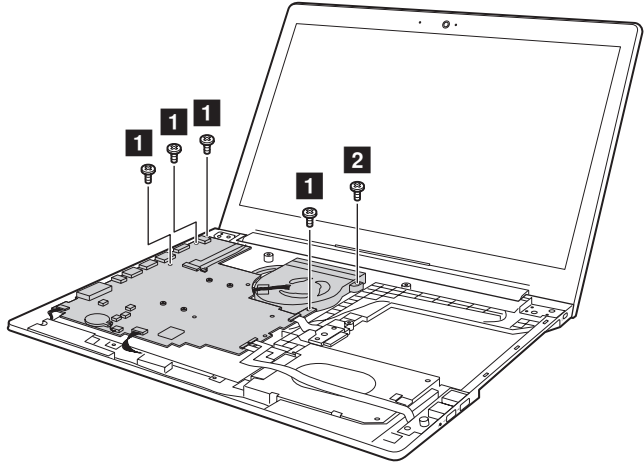

ideapad 310-14ISK:

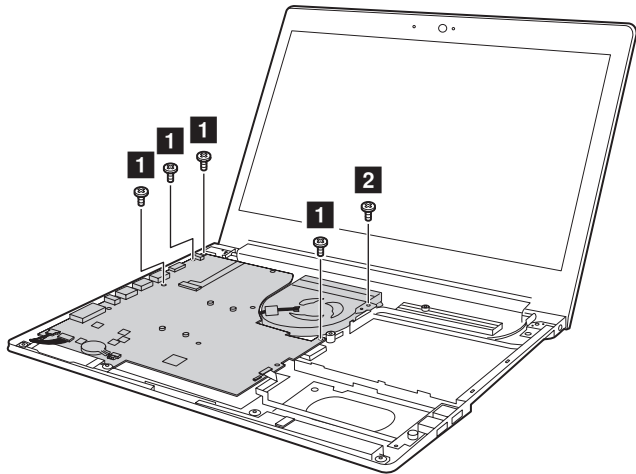

Step	Screw (quantity)	Color	Torque	PN
1	M2 × 3 mm, flat-head, nylok-coated (4)	Silver	1.85±0.15 kgfcm	90205117
	M2 × 6 mm, flat-head, nylok-coated(1)	Black	1.85±0.15 kgfcm	90205118

Figure 7. Removal steps of system board (continued)

ideapad 310-15ISK/ideapad 310 Touch-15ISK/ideapad 310-15ABR: Unplug speakers connector in the direction shown by arrow **3**, detach HDD connector in the direction shown by arrow **5**, detach ODD transfer board connector in the direction shown by arrow **7**, detach USB board connector in the direction shown by arrow **6**, disconnect battery connector in the direction shown by arrow **4**, disconnect camera connector in the direction shown by arrow **8**, detach LCD connector in the direction shown by arrow **9**.

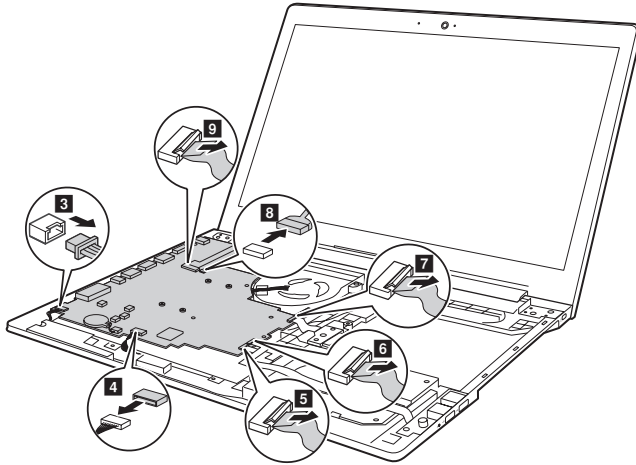

ideapad 310-14ISK: Unplug speakers connector in the direction shown by arrow **3**, detach USB board connector in the direction shown by arrow **5**, disconnect battery connector in the direction shown by arrow **4**, disconnect LCD connector in the direction shown by arrow **6**.

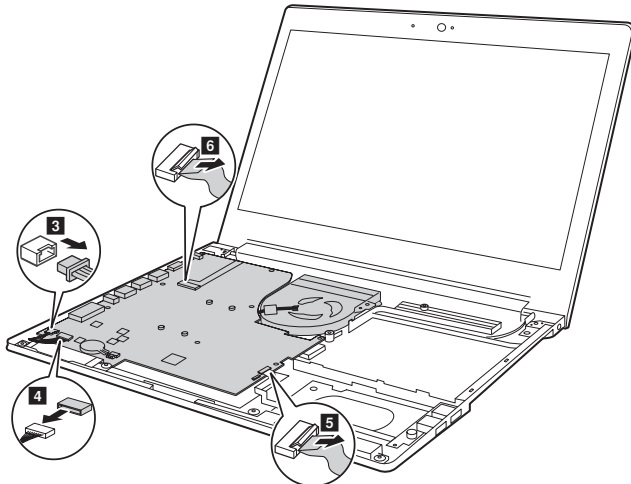

When installing: Make sure that all the connectors are attached firmly.

Figure 7. Removal steps of system board (continued)

Remove the system board in the direction shown by arrow **10**.

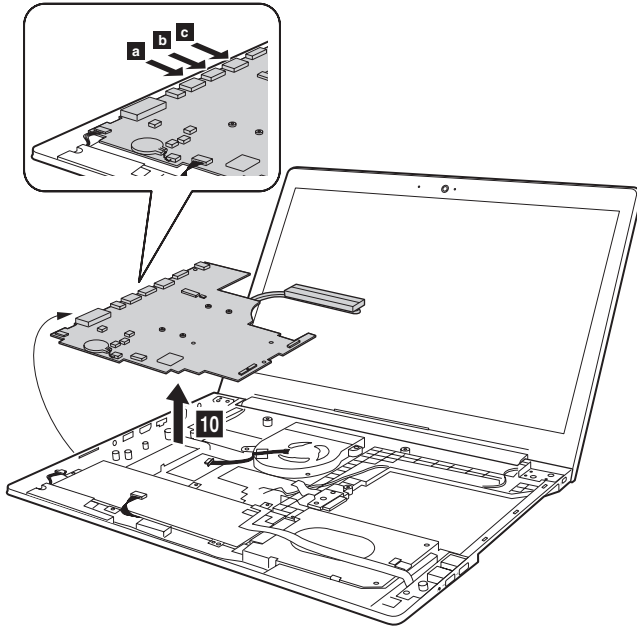

When installing: When attaching the system board to the base cover, adjust the placement of the USB, HDMI, RJ-45 ports as shown in **a b c**, and make sure that they are attached to the holes on the base cover as shown. Improper placement of those jacks might cause a damage.

1080 Fan assembly and Heat Sink assembly

For access, remove these FRUs in order:

- “1010 Hard disk drive(HDD) slot compartment cover” on page 35
- “1020 Hard disk drive” on page 36
- “1030 Memory/Mini PCI Express Card slot compartment cover and DIMM” on page 39
- “1040 PCI Express Mini Card for wireless LAN/WAN” on page 41
- “1050 Optical drive” on page 43
- “1060 Keyboard bezel” on page 44
- “1070 System board” on page 46

Figure 8. Removal steps of fan assembly and heat sink assembly

ideapad 310-15ISK/ideapad 310 Touch-15ISK/ideapad 310-15ABR: Unplug the fan connector in the direction shown by arrow **1** and loosen screws **2** to lift the fan assembly.

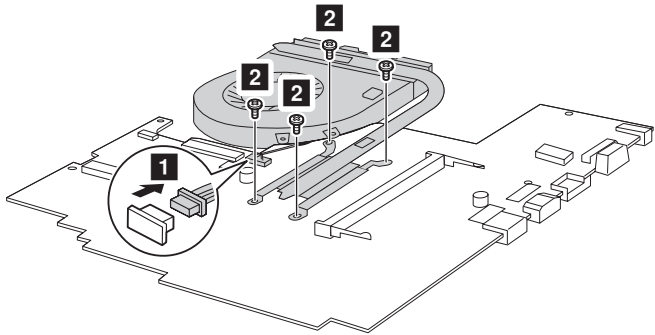
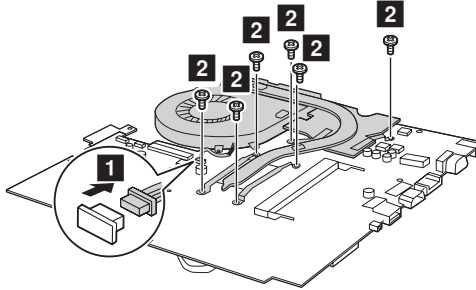

Figure 8. Removal steps of fan assembly and heat sink assembly (continued)

ideapad 310-14ISK: Unplug the fan connector in the direction shown by arrow **1** and loosen seven screws **2** to lift the fan assembly.



When installing: Make sure that the fan connector is attached firmly to the system board.

1090 LCD unit

For access, remove these FRUs in order

- “1010 Hard disk drive(HDD) slot compartment cover” on page 35
- “1020 Hard disk drive” on page 36
- “1030 Memory/Mini PCI Express Card slot compartment cover and DIMM” on page 39
- “1040 PCI Express Mini Card for wireless LAN/WAN” on page 41
- “1050 Optical drive” on page 43
- “1060 Keyboard bezel” on page 44
- “1070 System board” on page 46
- “1080 Fan assembly and Heat Sink assembly” on page 50

Figure 9. Removal steps of LCD unit

Remove the four screws **1**.

ideapad 310-15ISK/ideapad 310 Touch-15ISK/ideapad 310-15ABR:

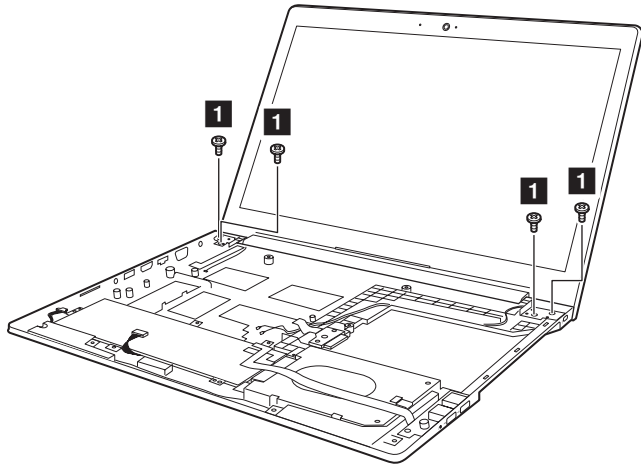

Step	Screw (quantity)	Color	Torque	PN
1	M2.5 × 3.5 mm, flat-head, nylok-coated (4) (ideapad 310-14ISK)	Silver	3±0.3 kgfcm	5S10K14049
	M2.5×4 mm, flat-head, nylok-coated (4) (ideapad 310-15ISK/ ideapad 310 Touch-15ISK/ ideapad 310-15ABR)	Black	3±0.3 kgfcm	90205119

Figure 9. Removal steps of LCD unit (continued)

Detach the LCD unit from the lower case.

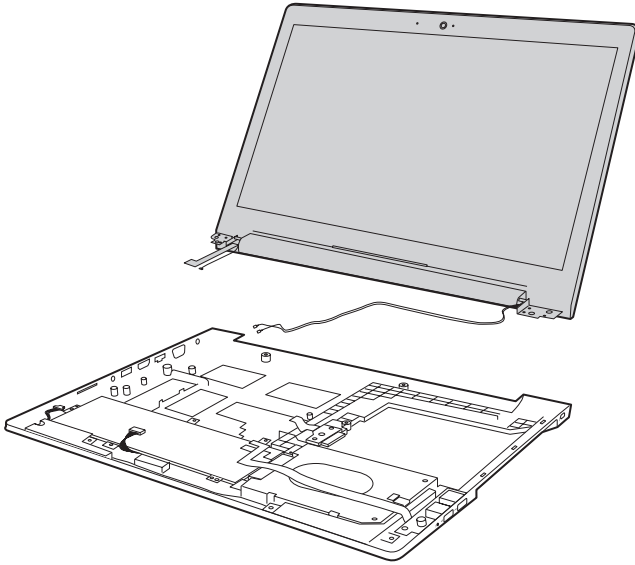

When installing:

- Route the antenna cables along the cable guides. As you route the cables, make sure that they are not subjected to any tension. Tension could cause the cables to be damaged by the cable guides, or a wire to be broken.
- Make sure that the LCD connector is attached firmly and make sure that you do not pinch the antenna cables when you attach the LCD assembly. Route the LCD cable along the cable guides.

1100 Battery pack

For access, remove these FRUs in order:

- “1010 Hard disk drive(HDD) slot compartment cover” on page 35
- “1020 Hard disk drive” on page 36
- “1030 Memory/Mini PCI Express Card slot compartment cover and DIMM” on page 39
- “1040 PCI Express Mini Card for wireless LAN/WAN” on page 41
- “1050 Optical drive” on page 43
- “1060 Keyboard bezel” on page 44
- “1070 System board” on page 46
- “1080 Fan assembly and Heat Sink assembly” on page 50
- “1090 LCD unit” on page 52

⚠ DANGER

Only use the battery specified in the parts list for your computer. Any other battery could ignite or explode.

Figure 10. Removal steps of battery pack

Remove the screws **1**. Remove the battery pack in the direction shown by arrow **2**.

ideapad 310-15ISK/ideapad 310 Touch-15ISK/ideapad 310-15ABR:

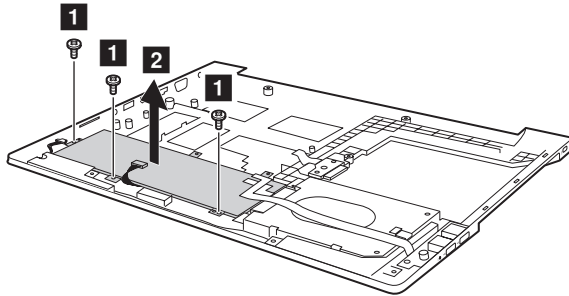
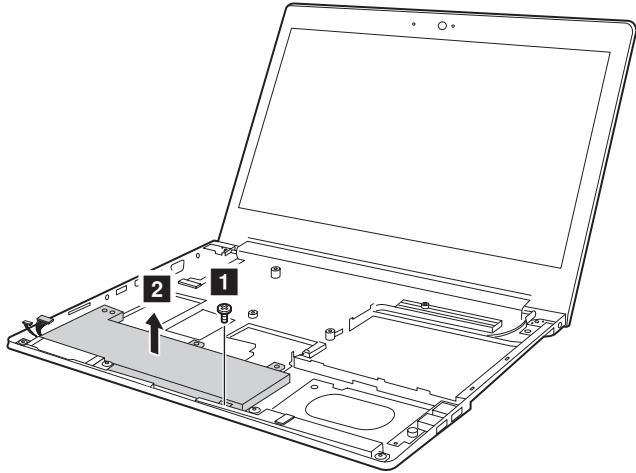

Figure 10. Removal steps of battery pack (continued)

Remove the screw **1**. Remove the battery pack in the direction shown by arrow

2

ideapad 310-14ISK:



Step	Screw (quantity)	Color	Torque
1	M2 × 6 mm, flat-head, nylok-coated (1) ideapad 310-14ISK	Black	1.85±0.15 kgfcm
1	M2 × 3 mm, flat-head, nylok-coated(3) ideapad 310-15ISK/ ideapad 310 Touch-15ISK/ ideapad 310-15ABR	Silver	1.85±0.15 kgfcm

When installing: Make sure that the battery connector is attached firmly.

1110 Speakers, base cover, USB board and ODD transfer board

For access, remove these FRUs in order:

- “1010 Hard disk drive(HDD) slot compartment cover” on page 35
- “1020 Hard disk drive” on page 36
- “1030 Memory/Mini PCI Express Card slot compartment cover and DIMM” on page 39
- “1040 PCI Express Mini Card for wireless LAN/WAN” on page 41
- “1050 Optical drive” on page 43
- “1060 Keyboard bezel” on page 44
- “1070 System board” on page 46
- “1080 Fan assembly and Heat Sink assembly” on page 50
- “1090 LCD unit” on page 52
- “1100 Battery pack” on page 54

Figure 11. Speakers, base cover, USB board and ODD transfer board

Remove the speakers in the direction shown by arrows **1**.

ideapad 310-15ISK/ideapad 310 Touch-15ISK/ideapad 310-15ABR:

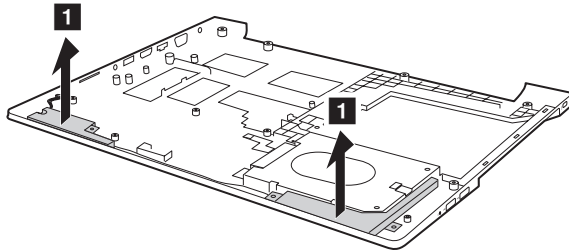

ideapad 310-14ISK:

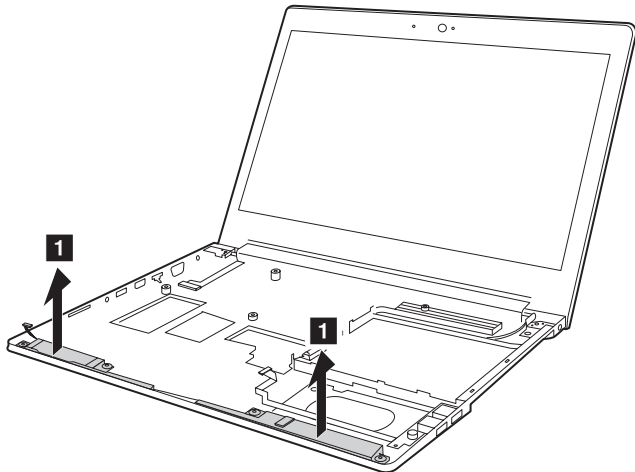
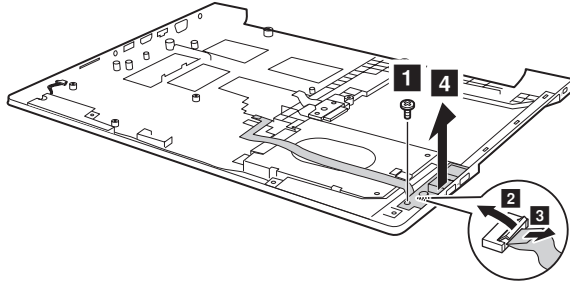

Figure 11. Speakers, base cover, USB board and ODD transfer board (continued)

Remove the screw **1**. Pull the USB board connector slot cover upward as shown by arrow **2**, detach the USB board cable from the keyboard connector in the direction shown by arrow **3**. Remove the USB board in the direction shown by arrow **4**.



When installing: Make sure that the USB board connector is attached firmly.

Step	Screw (quantity)	Color	Torque	PN
1	M2.0 × 3 mm, flat-head, nylok-coated (1)	Silver	1.85+/-0.15 kgfcm	90205117

Figure 11. Speakers, base cover, USB board and ODD transfer board (continued)

Remove screws **1**, lift the touch pad board in the direction shown by arrow **2**.

ideapad 310-15ISK/ideapad 310 Touch-15ISK/ideapad 310-15ABR:

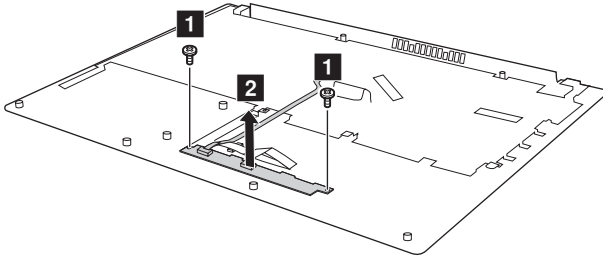

ideapad 310-14ISK:

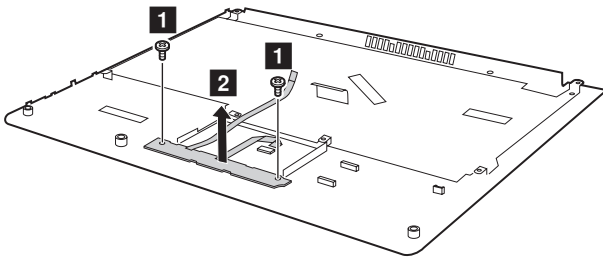

Step	Screw (quantity)	Color	Torque	PN
2	M2.0 × 3 mm, flat-head, nylok-coated (2)	Silver	1.85+/-0.15 kgfcm	90001118

When installing: Make sure that the touch pad board connector is attached firmly.

Figure 11. Speakers, base cover, USB board and ODD transfer board (continued)

Remove the screw **1** to lift the ODD transfer board in the direction shown by arrow **2**.

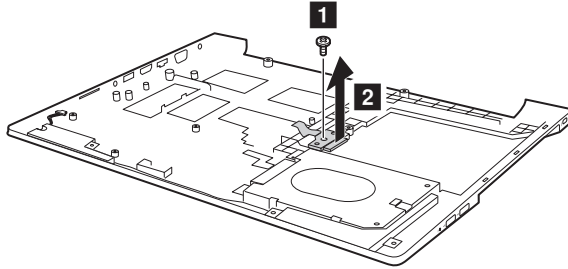

Step	Screw (quantity)	Color	Torque	PN
1	M2.0 × 3 mm, flat-head, nylok-coated (1)	Silver	1.85+/-0.15 kgfcm	90001118

When installing: Make sure that the ODD transfer board connector is attached firmly.

Applying labels to the base cover

The new base cover FRU is shipped with a kit containing labels of several kinds. Apply those labels when you replace the base cover. For labels which are not shipped with the new base cover, peel them from the replaced base cover and adhere them to the new one.

Note: If the Certificate of Authenticity (COA) label (b) is attached to a replaced part, return the replaced part to the customer, or provide a letter to the customer stating the original label part number, serial number, and product key.

The following letter shows the correct location of each label. Not all labels are attached on the part you are servicing.

- a** Rating label (66 × 24 mm)
- b** Rating label for print (43 × 24 mm)
- c** OS label
- d** BIS Label
- e** KCC Label
- f** Argentina label
- g** WL/BT Label
- h** Indonesia label

ideapad 310-14ISK:

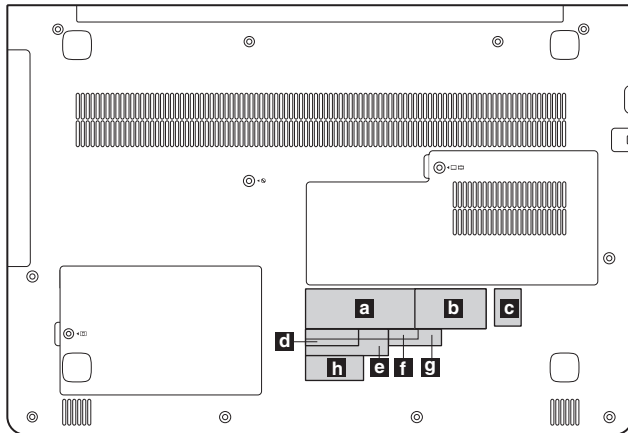

Applying labels to the base cover

The new base cover FRU is shipped with a kit containing labels of several kinds. Apply those labels when you replace the base cover. For labels which are not shipped with the new base cover, peel them from the replaced base cover and adhere them to the new one.

Note: If the Certificate of Authenticity (COA) label (b) is attached to a replaced part, return the replaced part to the customer, or provide a letter to the customer stating the original label part number, serial number, and product key.

The following letter shows the correct location of each label. Not all labels are attached on the part you are servicing.

- a** Rating label (66 × 24 mm)
- b** Rating label for print (43 × 24 mm)
- c** OS label
- d** BIS Label
- e** KCC Label
- f** Argentina label
- g** Indonesia label
- h** WL/BT Label

ideapad 310-15ISK/ideapad 310 Touch-15ISK/ideapad 310-15ABR:

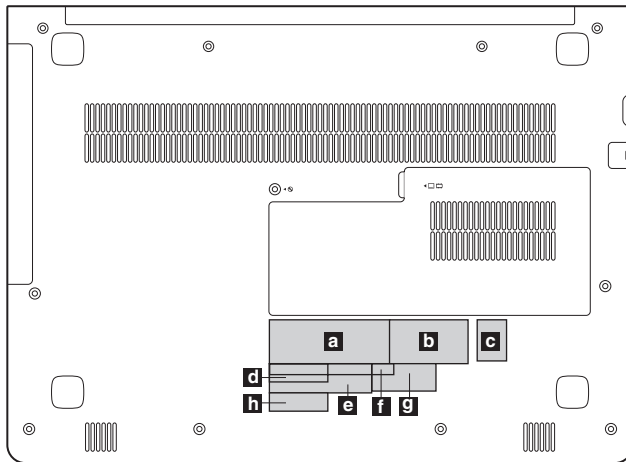

1120 LCD front bezel

For access, remove these FRUs in order:

- “1010 Hard disk drive(HDD) slot compartment cover” on page 35
- “1020 Hard disk drive” on page 36
- “1030 Memory/Mini PCI Express Card slot compartment cover and DIMM” on page 39
- “1040 PCI Express Mini Card for wireless LAN/WAN” on page 41
- “1050 Optical drive” on page 43
- “1060 Keyboard bezel” on page 44
- “1070 System board” on page 46
- “1080 Fan assembly and Heat Sink assembly” on page 50
- “1090 LCD unit” on page 52
- “1100 Battery pack” on page 54
- “1110 Speakers, base cover, USB board and ODD transfer board” on page 56

Figure 12. Removal steps of LCD front bezel

Remove the LCD front bezel in the direction by arrows **1**.

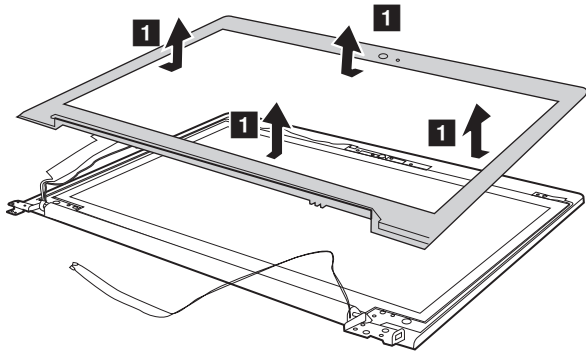

1130 LCD panel and LCD cable

For access, remove these FRUs in order:

- “1010 Hard disk drive(HDD) slot compartment cover” on page 35
- “1020 Hard disk drive” on page 36
- “1030 Memory/Mini PCI Express Card slot compartment cover and DIMM” on page 39
- “1040 PCI Express Mini Card for wireless LAN/WAN” on page 41
- “1050 Optical drive” on page 43
- “1060 Keyboard bezel” on page 44
- “1070 System board” on page 46
- “1080 Fan assembly and Heat Sink assembly” on page 50
- “1090 LCD unit” on page 52
- “1100 Battery pack” on page 54
- “1110 Speakers, base cover, USB board and ODD transfer board” on page 56
- “1120 LCD front bezel” on page 62

Figure 13. LCD panel and LCD cable

Remove four screws **1**.

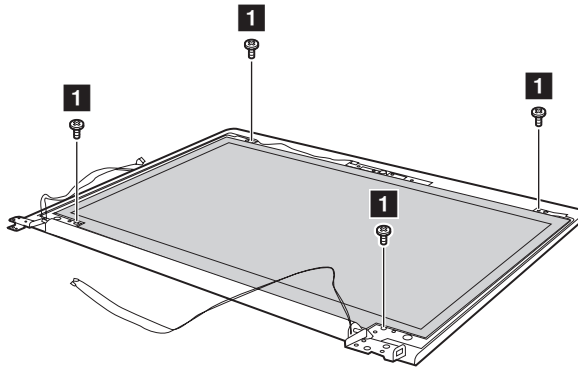

Step	Screw (quantity)	Color	Torque	PN
1	M2.0 × 3 mm, flat-head, nylok-coated (4)	Silver	1.85±0.15 kgfcm	90205117

Figure 13. LCD panel and LCD cable (continued)

Turn over the LCD module in the direction as shown by arrow **2**. Disconnect the connector by arrow **3** to remove the LCD panel.

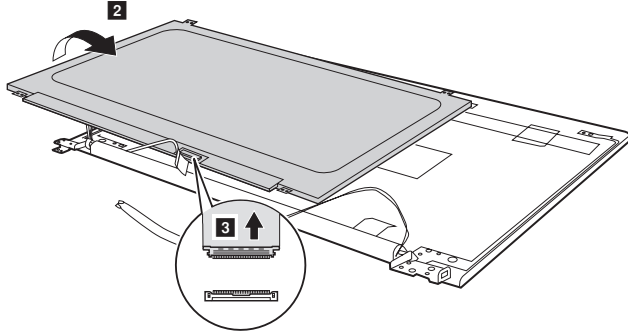

When installing: Make sure that the LCD panel connector is attached firmly.

1140 LCD hinges

For access, remove these FRUs in order:

- “1010 Hard disk drive(HDD) slot compartment cover” on page 35
- “1020 Hard disk drive” on page 36
- “1030 Memory/Mini PCI Express Card slot compartment cover and DIMM” on page 39
- “1040 PCI Express Mini Card for wireless LAN/WAN” on page 41
- “1050 Optical drive” on page 43
- “1060 Keyboard bezel” on page 44
- “1070 System board” on page 46
- “1080 Fan assembly and Heat Sink assembly” on page 50
- “1090 LCD unit” on page 52
- “1100 Battery pack” on page 54
- “1110 Speakers, base cover, USB board and ODD transfer board” on page 56
- “1120 LCD front bezel” on page 62
- “1130 LCD panel and LCD cable” on page 63

Figure 14. Removal steps of hinges

Remove screws **1**. Remove the hinges in the direction shown by arrows **2**.

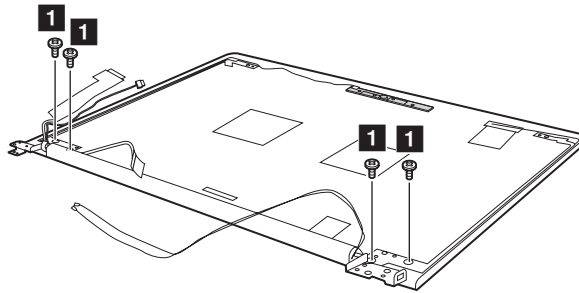

Step	Screw (quantity)	Color	Torque	PN
1	M2.5 × 2.5 mm, flat-head, nylok-coated (4)	Black	3 ± 0.3 kgfcm	5S10K26863

1150 Integrated camera

For access, remove these FRUs in order:

- “1010 Hard disk drive(HDD) slot compartment cover” on page 35
- “1020 Hard disk drive” on page 36
- “1030 Memory/Mini PCI Express Card slot compartment cover and DIMM” on page 39
- “1040 PCI Express Mini Card for wireless LAN/WAN” on page 41
- “1050 Optical drive” on page 43
- “1060 Keyboard bezel” on page 44
- “1070 System board” on page 46
- “1080 Fan assembly and Heat Sink assembly” on page 50
- “1090 LCD unit” on page 52
- “1100 Battery pack” on page 54
- “1110 Speakers, base cover, USB board and ODD transfer board” on page 56
- “1120 LCD front bezel” on page 62
- “1130 LCD panel and LCD cable” on page 63
- “1140 LCD hinges” on page 65

Figure 15. Removal steps of integrated camera

Note: The integrated camera is stuck on the top center of the LCD cover.

Unplug the connector in the direction shown by arrow **1**, remove the integrated camera from the LCD cover in the direction shown by arrow **2**.

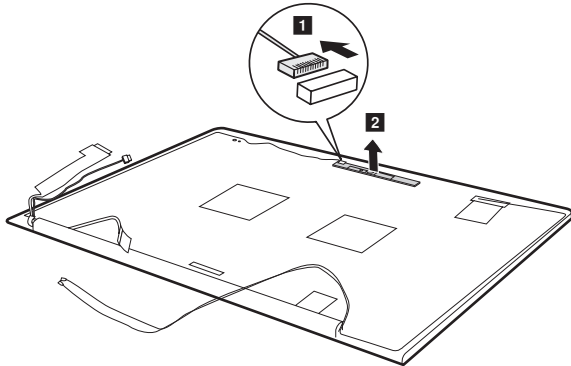

When installing: Stick the integrated camera to the top center of the LCD cover and adjust the placement of it to make sure the connector is attached firmly.

1160 Antenna assembly and LCD cover

For access, remove these FRUs in order:

- “1010 Hard disk drive(HDD) slot compartment cover” on page 35
- “1020 Hard disk drive” on page 36
- “1030 Memory/Mini PCI Express Card slot compartment cover and DIMM” on page 39
- “1040 PCI Express Mini Card for wireless LAN/WAN” on page 41
- “1050 Optical drive” on page 43
- “1060 Keyboard bezel” on page 44
- “1070 System board” on page 46
- “1080 Fan assembly and Heat Sink assembly” on page 50
- “1090 LCD unit” on page 52
- “1100 Battery pack” on page 54
- “1110 Speakers, base cover, USB board and ODD transfer board” on page 56
- “1120 LCD front bezel” on page 62
- “1130 LCD panel and LCD cable” on page 63
- “1140 LCD hinges” on page 65
- “1150 Integrated camera” on page 66

Figure 16. Removal steps of antenna assembly and LCD cover

Peel off the adhesive tapes securing the antenna boards, release the cables from the cable guide, and then remove the antenna assembly in the direction shown by arrows **1**.

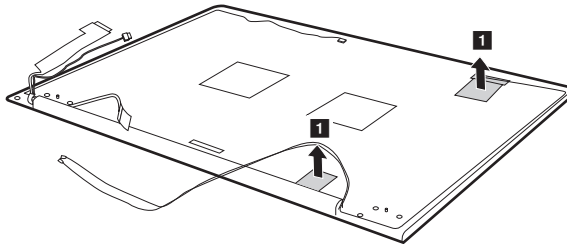

When installing: Route the antenna cables along the cable guides and secure the antenna boards with adhesive tapes. As you route the cables, make sure that they are not subjected to any tension. Tension could cause the cables to be damaged by the cable guides, or a wire to be broken.

Locations

Front view

- 1** Integrated camera
- 2** Built-in microphone
- 3** Wireless LAN antennas
- 4** Computer display (ideapad 310-14ISK/ideapad 310-15ISK/ideapad 310-15ABR) /Multi-touch screen (ideapad 310 Touch-15ISK)
- 5** Power button
- 6** Ventilation slots
- 7** Touch pad
- 8** Numeric keypad

ideapad 310-14ISK:

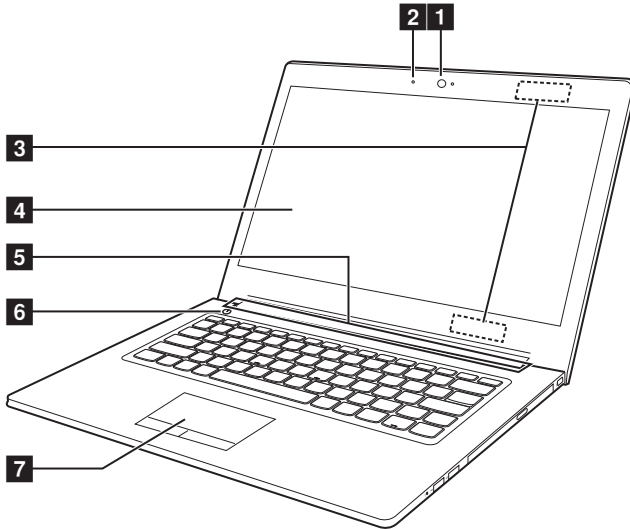

ideapad 310-15ISK/ideapad 310 Touch-15ISK/ideapad 310-15ABR:

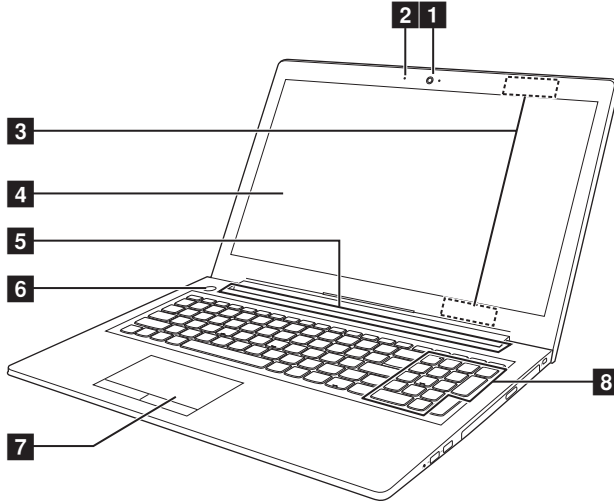

Bottom and Left-side view

- 1** Ventilation slots
- 2** Bottom slot cover
- 3** Speakers
- 4** AC power adapter jack
- 5** Battery/Charging status indicator
- 6** VGA port
- 7** RJ-45 port
- 8** HDMI port
- 9** USB 3.0 port
- 10** Combo audio jack
- 11** Novo button
- 12** Memory card slot

ideapad 310-15ISK/ideapad 310 Touch-15ISK/ideapad 310-15ABR

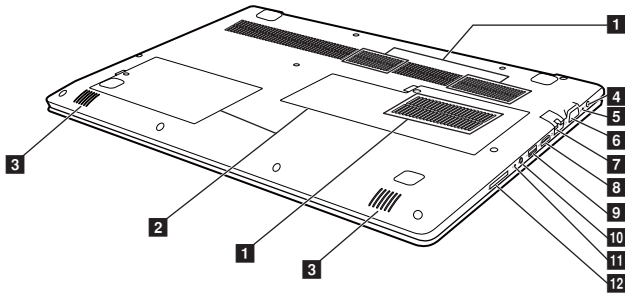

ideapad 310-14ISK

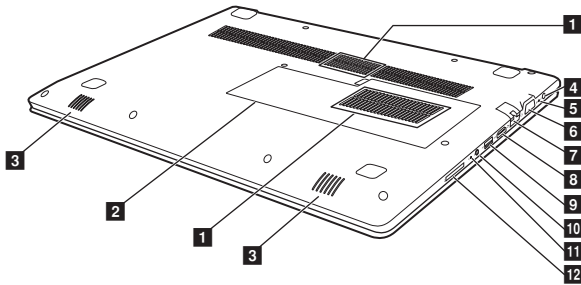

Right-side view

- 1** Power status indicator
- 2** USB port
- 3** Optical disc drive
- 4** Kensington slot

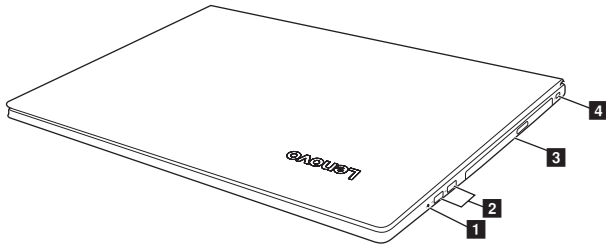

Parts list

This section presents the following service parts:

- “Overall” on page 73
- “LCD FRUs” on page 94
- “Miscellaneous parts” on page 98
- “AC adapters” on page 100
- “Power cords” on page 105

Notes:

- Each FRU is available for all types or models, unless specific types or models are specified.

Overall

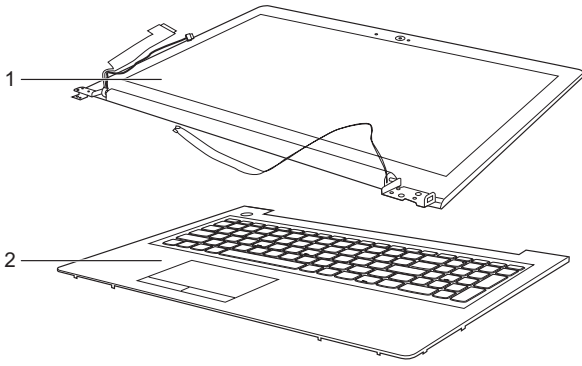

ideapad 310-14ISK

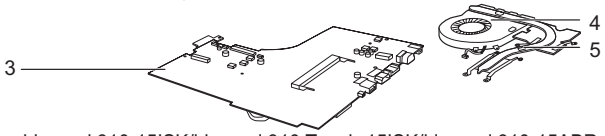

ideapad 310-15ISK/ideapad 310 Touch-15ISK/ideapad 310-15ABR

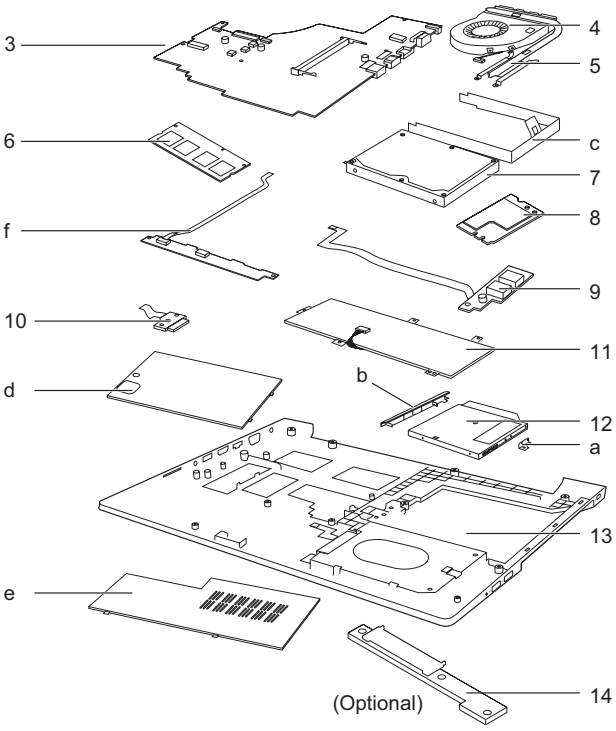

// *Lenovo ideapad 310-14ISK/ideapad 310-15ISK/ideapad 310 Touch-15ISK/ideapad 310-15ABR Hardware Maintenance Manual*

Table 4. Parts list—Overall

No.	FRU	FRU no.	CRU ID	ideapad 310-14ISK	ideapad 310-15ISK/ideapad 310-15ABR	ideapad 310-15ISK Touch
a-f	see “Miscellaneous parts” on page 98.					
1	LCD unit (see “LCD FRUs” on page 94.)					
2	Upper Case ASML80SLREDIMR US KB	5CB0L35749	N	●		
2	Upper Case ASML80SLREDIMR UK KB	5CB0L35798	N	●		
2	Upper Case ASML80SLREDIMR ITA KB	5CB0L35684	N	●		
2	Upper Case ASML80SLREDIMR SPA KB	5CB0L35788	N	●		
2	Upper Case ASML80SLREDIMR TUR KB	5CB0L35758	N	●		
2	Upper Case ASML80SLREDIMR THAI KB	5CB0L35771	N	●		
2	Upper Case ASML80SLREDIMR POR KB	5CB0L35753	N	●		
2	Upper Case ASML80SLREDIMR LASPA KB	5CB0L35711	N	●		
2	Upper Case ASML80SLREDIMR CFEN KB	5CB0L35687	N	●		
2	Upper Case ASML80SLREDIMR KOR KB	5CB0L35752	N	●		
2	Upper Case ASML80SLREDIMR TC KB	5CB0L35748	N	●		
2	Upper Case ASML80SLREDIMR RUS KB	5CB0L35723	N	●		
2	Upper Case ASML80SLREDIMR FRA KB	5CB0L35724	N	●		

Table 4. Parts list—Overall (continued)

No.	FRU	FRU no.	CRU ID	ideapad 310-14ISK	ideapad 310-15ISK/ideapad 310-15ABR	ideapad 310-15ISK Touch
2	Upper CaseASML80SLREDIMR GER KB	5CB0L35700	N	●		
2	Upper CaseASML80SLREDIMR ARA KB	5CB0L35710	N	●		
2	Upper CaseASML80SLREDIMR BRL KB	5CB0L35719	N	●		
2	Upper CaseASML80SLREDIMR JP KB	5CB0L35780	N	●		
2	Upper CaseASML80SLREDIMR DUTCH KB	5CB0L35754	N	●		
2	Upper CaseASML80SLREDIMR GRE KB	5CB0L35715	N	●		
2	Upper CaseASML80SLREDIMR HBW KB	5CB0L35721	N	●		
2	Upper CaseASML80SLREDIMR HUN KB	5CB0L35717	N	●		
2	Upper CaseASML80SLREDIMR NORDIC KB	5CB0L35730	N	●		
2	Upper CaseASML80SLREDIMR BEL KB	5CB0L35703	N	●		
2	Upper CaseASML80SLREDIMR ILD KB	5CB0L35778	N	●		
2	Upper CaseASML80SLREDIMR SLV KB	5CB0L35702	N	●		
2	Upper CaseASML80SLREDIMR SWS KB	5CB0L35785	N	●		
2	Upper CaseASML80SLREDIMR USINTERKB	5CB0L35777	N	●		

Lenovo ideapad 310-14ISK/ideapad 310-15ISK/ideapad 310 Touch-15ISK/ideapad 310-15ABR Hardware Maintenance Manual

Table 4. Parts list—Overall (continued)

No.	FRU	FRU no.	CRU ID	ideapad 310-14ISK	ideapad 310-15ISK/ideapad 310-15ABR	ideapad 310-15ISK Touch
2	Upper CaseASML80SLREDIMR CZE_SLK KB	5CB0L35807	N	●		
2	Upper CaseASML80SLREDIMR BUL KB	5CB0L35736	N	●		
2	Upper CaseASML80SLREDIMR IND KB	5CB0L35770	N	●		
2	Upper CaseASML80SLREDIMR FRA/ARA KB	5CB0L35691	N	●		
2	Upper CaseASML80SLBKIMR US KB	5CB0L35792	N	●		
2	Upper CaseASML80SLBKIMR UK KB	5CB0L35779	N	●		
2	Upper CaseASML80SLBKIMR ITA KB	5CB0L35686	N	●		
2	Upper CaseASML80SLBKIMR SPA KB	5CB0L35774	N	●		
2	Upper CaseASML80SLBKIMR TUR KB	5CB0L35794	N	●		
2	Upper CaseASML80SLBKIMR THAI KB	5CB0L35793	N	●		
2	Upper CaseASML80SLBKIMR POR KB	5CB0L35694	N	●		
2	Upper CaseASML80SLBKIMR LASPA KB	5CB0L35776	N	●		
2	Upper CaseASML80SLBKIMR CFEN KB	5CB0L35786	N	●		
2	Upper CaseASML80SLBKIMR KOR KB	5CB0L35808	N	●		

Table 4. Parts list—Overall (continued)

No.	FRU	FRU no.	CRU ID	ideapad 310-14ISK	ideapad 310-15ISK/ideapad 310-15ABR	ideapad 310-15ISK Touch
2	Upper CaseASML80SLBKIMR TC KB	5CB0L35697	N	●		
2	Upper CaseASML80SLBKIMR RUS KB	5CB0L35760	N	●		
2	Upper CaseASML80SLBKIMR FRA KB	5CB0L35763	N	●		
2	Upper CaseASML80SLBKIMR GER KB	5CB0L35787	N	●		
2	Upper CaseASML80SLBKIMR ARA KB	5CB0L35692	N	●		
2	Upper CaseASML80SLBKIMR BRL KB	5CB0L35761	N	●		
2	Upper CaseASML80SLBKIMR JP KB	5CB0L35722	N	●		
2	Upper CaseASML80SLBKIMR DUTCH KB	5CB0L35746	N	●		
2	Upper CaseASML80SLBKIMR GRE KB	5CB0L35701	N	●		
2	Upper CaseASML80SLBKIMR HBW KB	5CB0L35783	N	●		
2	Upper CaseASML80SLBKIMR HUN KB	5CB0L35693	N	●		
2	Upper CaseASML80SLBKIMR NORDIC KB	5CB0L35728	N	●		
2	Upper CaseASML80SLBKIMR BEL KB	5CB0L35805	N	●		
2	Upper CaseASML80SLBKIMR ILD KB	5CB0L35759	N	●		

// Lenovo ideapad 310-14ISK/ideapad 310-15ISK/ideapad 310 Touch-15ISK/ideapad 310-15ABR Hardware Maintenance Manual

Table 4. Parts list—Overall (continued)

No.	FRU	FRU no.	CRU ID	ideapad 310-14ISK	ideapad 310-15ISK/ideapad 310-15ABR	ideapad 310-15ISK Touch
2	Upper CaseASML80SLBKIMR SLV KB	5CB0L35747	N	●		
2	Upper CaseASML80SLBKIMR SWS KB	5CB0L35732	N	●		
2	Upper CaseASML80SLBKIMRU SINTERKB	5CB0L35689	N	●		
2	Upper CaseASML80SLBKIMR CZE_SLK KB	5CB0L35712	N	●		
2	Upper CaseASML80SLBKIMR BUL KB	5CB0L35695	N	●		
2	Upper CaseASML80SLBKIMR IND KB	5CB0L35708	N	●		
2	Upper CaseASML80SLBKIMR FRA / ARA KB	5CB0L35756	N	●		
2	Upper CaseASML80SLSRIMR US KB	5CB0L35757	N	●		
2	Upper CaseASML80SLSRIMR UK KB	5CB0L35685	N	●		
2	Upper CaseASML80SLSRIMR ITA KB	5CB0L35789	N	●		
2	Upper CaseASML80SLSRIMR SPA KB	5CB0L35768	N	●		
2	Upper CaseASML80SLSRIMR TUR KB	5CB0L35706	N	●		
2	Upper CaseASML80SLSRIMR THAI KB	5CB0L35705	N	●		
2	Upper CaseASML80SLSRIMR POR KB	5CB0L35790	N	●		

Lenovo ideapad 310-14ISK/ideapad 310-15ISK/ideapad 310 Touch-15ISK/

Table 4. Parts list—Overall (continued)

No.	FRU	FRU no.	CRU ID	ideapad 310-14ISK	ideapad 310-15ISK/ideapad 310-15ABR	ideapad 310-15ISK Touch
2	Upper CaseASML80SLSRIMR LASPA KB	5CB0L35688	N	●		
2	Upper CaseASML80SLSRIMR CFEN KB	5CB0L35716	N	●		
2	Upper CaseASML80SLSRIMR KOR KB	5CB0L35769	N	●		
2	Upper CaseASML80SLSRIMR TC KB	5CB0L35690	N	●		
2	Upper CaseASML80SLSRIMR RUS KB	5CB0L35735	N	●		
2	Upper CaseASML80SLSRIMR FRA KB	5CB0L35772	N	●		
2	Upper CaseASML80SLSRIMR GER KB	5CB0L35801	N	●		
2	Upper CaseASML80SLSRIMR ARA KB	5CB0L35714	N	●		
2	Upper CaseASML80SLSRIMR BRL KB	5CB0L35696	N	●		
2	Upper CaseASML80SLSRIMR JP KB	5CB0L35744	N	●		
2	Upper CaseASML80SLSRIMR DUTCH KB	5CB0L35733	N	●		
2	Upper CaseASML80SLSRIMR GRE KB	5CB0L35806	N	●		
2	Upper CaseASML80SLSRIMR HBW KB	5CB0L35720	N	●		
2	Upper CaseASML80SLSRIMR HUN KB	5CB0L35762	N	●		

Lenovo ideapad 310-14ISK/ideapad 310-15ISK/ideapad 310 Touch-15ISK/ideapad 310-15ABR Hardware Maintenance Manual

Table 4. Parts list—Overall (continued)

No.	FRU	FRU no.	CRU ID	ideapad 310-14ISK	ideapad 310-15ISK/ideapad 310-15ABR	ideapad 310-15ISK Touch
2	Upper CaseASML80SLSRIMR NORDIC KB	5CB0L35781	N	●		
2	Upper CaseASML80SLSRIMR BEL KB	5CB0L35784	N	●		
2	Upper CaseASML80SLSRIMR ILD KB	5CB0L35750	N	●		
2	Upper CaseASML80SLSRIMR SLV KB	5CB0L35755	N	●		
2	Upper CaseASML80SLSRIMR SWS KB	5CB0L35797	N	●		
2	Upper CaseASML80SLSRIMRU SINTERKB	5CB0L35795	N	●		
2	Upper CaseASML80SLSRIMR CZE_SLK KB	5CB0L35740	N	●		
2	Upper CaseASML80SLSRIMR BUL KB	5CB0L35726	N	●		
2	Upper CaseASML80SLSRIMR IND KB	5CB0L35739	N	●		
2	Upper CaseASML80SLSRIMR FRA/ARA KB	5CB0L35796	N	●		
2	Lower CaseASML80SLBK TEX W/SPEAKER	5CB0L35698	N	●		
2	Upper Case ASM L80SMREDIMR US KB	5CB0L35876	N		●	
2	Upper Case ASM L80SMREDIMR UK KB	5CB0L35850	N		●	
2	Upper Case ASM L80SMREDIMR ITA KB	5CB0L35902	N		●	
2	Upper Case ASM L80SMREDIMR SPA KB	5CB0L35915	N		●	
2	Upper Case ASM L80SMREDIMR TUR KB	5CB0L35911	N		●	

Lenovo ideapad 310-14ISK/ideapad 310-15ISK/ideapad 310 Touch-15ISK/

Table 4. Parts list—Overall (continued)

No.	FRU	FRU no.	CRU ID	ideapad 310-14ISK	ideapad 310-15ISK/ideapad 310-15ABR	ideapad 310-15ISK Touch
2	Upper Case ASM L80SMREDIMR THAI KB	5CB0L35861	N		●	
2	Upper Case ASM L80SMREDIMR POR KB	5CB0L35908	N		●	
2	Upper Case ASM L80SMREDIMR LASPA KB	5CB0L35843	N		●	
2	Upper Case ASM L80SMREDIMR CFEN KB	5CB0L35932	N		●	
2	Upper Case ASM L80SMREDIMR KOR KB	5CB0L35886	N		●	
2	Upper Case ASM L80SMREDIMR TC KB	5CB0L35881	N		●	
2	Upper Case ASM L80SMREDIMR RUS KB	5CB0L35892	N		●	
2	Upper Case ASM L80SMREDIMR FRA KB	5CB0L35866	N		●	
2	Upper Case ASM L80SMREDIMR GER KB	5CB0L35910	N		●	
2	Upper Case ASM L80SMREDIMR ARA KB	5CB0L35891	N		●	
2	Upper Case ASM L80SMREDIMR BRL KB	5CB0L35912	N		●	
2	Upper Case ASM L80SMREDIMR JP KB	5CB0L35868	N		●	
2	Upper Case ASM L80SMREDIMR DUTCH KB	5CB0L35849	N		●	
2	Upper Case ASM L80SMREDIMR GRE KB	5CB0L35916	N		●	
2	Upper Case ASM L80SMREDIMR HBW KB	5CB0L35819	N		●	
2	Upper Case ASM L80SMREDIMR HUN KB	5CB0L35832	N		●	
2	Upper Case ASM L80SMREDIMR NORDIC KB	5CB0L35924	N		●	
2	Upper Case ASM L80SMREDIMR BEL KB	5CB0L35835	N		●	
2	Upper Case ASM L80SMREDIMR ILD KB	5CB0L35863	N		●	

// *Lenovo ideapad 310-14ISK/ideapad 310-15ISK/ideapad 310 Touch-15ISK/ideapad 310-15ABR Hardware Maintenance Manual*

Table 4. Parts list—Overall (continued)

No.	FRU	FRU no.	CRU ID	ideapad 310-14ISK	ideapad 310-15ISK/ ideapad 310-15ABR	ideapad 310-15ISK Touch
2	Upper Case ASM L80SMREDIMR SLV KB	5CB0L35903	N		●	
2	Upper Case ASM L80SMREDIMR SWS KB	5CB0L35817	N		●	
2	Upper Case ASM L80SMREDIMRUSINTE RKB	5CB0L35834	N		●	
2	Upper Case ASM L80SMREDIMR CZE_SLK KB	5CB0L35882	N		●	
2	Upper Case ASM L80SMREDIMR BUL KB	5CB0L35836	N		●	
2	Upper Case ASM L80SMREDIMR IND KB	5CB0L35906	N		●	
2	Upper Case ASM L80SMREDIMR FRA/ ARA KB	5CB0L35885	N		●	
2	Upper Case ASM L80SMBKIMR US KB	5CB0L35842	N		●	
2	Upper Case ASM L80SMBKIMR UK KB	5CB0L35894	N		●	
2	Upper Case ASM L80SMBKIMR ITA KB	5CB0L35824	N		●	
2	Upper Case ASM L80SMBKIMR SPA KB	5CB0L35853	N		●	
2	Upper Case ASM L80SMBKIMR TUR KB	5CB0L35878	N		●	
2	Upper Case ASM L80SMBKIMR THAI KB	5CB0L35830	N		●	
2	Upper Case ASM L80SMBKIMR POR KB	5CB0L35919	N		●	
2	Upper Case ASM L80SMBKIMR LASPA KB	5CB0L35828	N		●	
2	Upper Case ASM L80SMBKIMR CFEN KB	5CB0L35920	N		●	
2	Upper Case ASM L80SMBKIMR KOR KB	5CB0L35838	N		●	
2	Upper Case ASM L80SMBKIMR TC KB	5CB0L35918	N		●	
2	Upper Case ASM L80SMBKIMR RUS KB	5CB0L35825	N		●	

Table 4. Parts list—Overall (continued)

No.	FRU	FRU no.	CRU ID	ideapad 310-14ISK	ideapad 310-15ISK/ideapad 310-15ABR	ideapad 310-15ISK Touch
2	Upper Case ASM L80SMBKIMR FRA KB	5CB0L35845	N		●	
2	Upper Case ASM L80SMBKIMR GER KB	5CB0L35826	N		●	
2	Upper Case ASM L80SMBKIMR ARA KB	5CB0L35829	N		●	
2	Upper Case ASM L80SMBKIMR BRL KB	5CB0L35827	N		●	
2	Upper Case ASM L80SMBKIMR JP KB	5CB0L35884	N		●	
2	Upper Case ASM L80SMBKIMR DUTCH KB	5CB0L35872	N		●	
2	Upper Case ASM L80SMBKIMR GRE KB	5CB0L35895	N		●	
2	Upper Case ASM L80SMBKIMR HBW KB	5CB0L35905	N		●	
2	Upper Case ASM L80SMBKIMR HUN KB	5CB0L35837	N		●	
2	Upper Case ASM L80SMBKIMR NORDIC KB	5CB0L35921	N		●	
2	Upper Case ASM L80SMBKIMR BEL KB	5CB0L35814	N		●	
2	Upper Case ASM L80SMBKIMR ILD KB	5CB0L35855	N		●	
2	Upper Case ASM L80SMBKIMR SLV KB	5CB0L35841	N		●	
2	Upper Case ASM L80SMBKIMR SWS KB	5CB0L35869	N		●	
2	Upper Case ASM L80SMBKIMRUSINTER KB	5CB0L35820	N		●	
2	Upper Case ASM L80SMBKIMR CZE_SLK KB	5CB0L35909	N		●	
2	Upper Case ASM L80SMBKIMR BUL KB	5CB0L35821	N		●	
2	Upper Case ASM L80SMBKIMR IND KB	5CB0L35926	N		●	
2	Upper Case ASM L80SMBKIMR FRA/ ARA KB	5CB0L35867	N		●	

Lenovo ideapad 310-14ISK/ideapad 310-15ISK/ideapad 310 Touch-15ISK/ideapad 310-15ABR Hardware Maintenance Manual

Table 4. Parts list—Overall (continued)

No.	FRU	FRU no.	CRU ID	ideapad 310-14ISK	ideapad 310-15ISK/ideapad 310-15ABR	ideapad 310-15ISK Touch
2	Upper Case ASM L80SMSRIMR US KB	5CB0L35874	N		●	
2	Upper Case ASM L80SMSRIMR UK KB	5CB0L35852	N		●	
2	Upper Case ASM L80SMSRIMR ITA KB	5CB0L35877	N		●	
2	Upper Case ASM L80SMSRIMR SPA KB	5CB0L35862	N		●	
2	Upper Case ASM L80SMSRIMR TUR KB	5CB0L35904	N		●	
2	Upper Case ASM L80SMSRIMR THAI KB	5CB0L35848	N		●	
2	Upper Case ASM L80SMSRIMR POR KB	5CB0L35923	N		●	
2	Upper Case ASM L80SMSRIMR LASPA KB	5CB0L35851	N		●	
2	Upper Case ASM L80SMSRIMR CFEN KB	5CB0L35813	N		●	
2	Upper Case ASM L80SMSRIMR KOR KB	5CB0L35907	N		●	
2	Upper Case ASM L80SMSRIMR TC KB	5CB0L35839	N		●	
2	Upper Case ASM L80SMSRIMR RUS KB	5CB0L35925	N		●	
2	Upper Case ASM L80SMSRIMR FRA KB	5CB0L35818	N		●	
2	Upper Case ASM L80SMSRIMR GER KB	5CB0L35840	N		●	
2	Upper Case ASM L80SMSRIMR ARA KB	5CB0L35879	N		●	
2	Upper Case ASM L80SMSRIMR BRL KB	5CB0L35900	N		●	
2	Upper Case ASM L80SMSRIMR JP KB	5CB0L35816	N		●	
2	Upper Case ASM L80SMSRIMR DUTCH KB	5CB0L35854	N		●	
2	Upper Case ASM L80SMSRIMR GRE KB	5CB0L35871	N		●	
2	Upper Case ASM L80SMSRIMR HBW KB	5CB0L35922	N		●	
2	Upper Case ASM L80SMSRIMR HUN KB	5CB0L35893	N		●	

Table 4. Parts list—Overall (continued)

No.	FRU	FRU no.	CRU ID	ideapad 310-14ISK	ideapad 310-15ISK/ideapad 310-15ABR	ideapad 310-15ISK Touch
2	Upper Case ASM L80SMSRIMR NORDIC KB	5CB0L35857	N		●	
2	Upper Case ASM L80SMSRIMR BEL KB	5CB0L35889	N		●	
2	Upper Case ASM L80SMSRIMR ILD KB	5CB0L35880	N		●	
2	Upper Case ASM L80SMSRIMR SLV KB	5CB0L35844	N		●	
2	Upper Case ASM L80SMSRIMR SWS KB	5CB0L35823	N		●	
2	Upper Case ASM L80SMSRIMRUSINTER KB	5CB0L35883	N		●	
2	Upper Case ASM L80SMSRIMR CZE_SLK KB	5CB0L35913	N		●	
2	Upper Case ASM L80SMSRIMR BUL KB	5CB0L35931	N		●	
2	Upper Case ASM L80SMSRIMR IND KB	5CB0L35875	N		●	
2	Upper Case ASM L80SMSRIMR FRA / ARA KB	5CB0L35887	N		●	
2	Upper Case ASM L80SMPLIMR US KB	5CB0L46871	N		●	
2	Upper Case ASM L80SMPLIMR UK KB	5CB0L46874	N		●	
2	Upper Case ASM L80SMPLIMR ITA KB	5CB0L46872	N		●	
2	Upper Case ASM L80SMPLIMR SPA KB	5CB0L46886	N		●	
2	Upper Case ASM L80SMPLIMR TUR KB	5CB0L46866	N		●	
2	Upper Case ASM L80SMPLIMR THAI KB	5CB0L46879	N		●	
2	Upper Case ASM L80SMPLIMR POR KB	5CB0L46896	N		●	
2	Upper Case ASM L80SMPLIMR LASPA KB	5CB0L46875	N		●	
2	Upper Case ASM L80SMPLIMR CFEN KB	5CB0L46893	N		●	

Lenovo ideapad 310-14ISK/ideapad 310-15ISK/ideapad 310 Touch-15ISK/ideapad 310-15ABR Hardware Maintenance Manual

Table 4. Parts list—Overall (continued)

No.	FRU	FRU no.	CRU ID	ideapad 310-14ISK	ideapad 310-15ISK/ideapad 310-15ABR	ideapad 310-15ISK Touch
2	Upper Case ASM L80SMPLIMR KOR KB	5CB0L46892	N		●	
2	Upper Case ASM L80SMPLIMR TC KB	5CB0L46882	N		●	
2	Upper Case ASM L80SMPLIMR RUS KB	5CB0L46890	N		●	
2	Upper Case ASM L80SMPLIMR FRA KB	5CB0L46867	N		●	
2	Upper Case ASM L80SMPLIMR GER KB	5CB0L46880	N		●	
2	Upper Case ASM L80SMPLIMR ARA KB	5CB0L46883	N		●	
2	Upper Case ASM L80SMPLIMR BRL KB	5CB0L46897	N		●	
2	Upper Case ASM L80SMPLIMR JP KB	5CB0L46884	N		●	
2	Upper Case ASM L80SMPLIMR DUTCH KB	5CB0L46895	N		●	
2	Upper Case ASM L80SMPLIMR GRE KB	5CB0L46873	N		●	
2	Upper Case ASM L80SMPLIMR HBW KB	5CB0L46894	N		●	
2	Upper Case ASM L80SMPLIMR HUN KB	5CB0L46887	N		●	
2	Upper Case ASM L80SMPLIMR NORDIC KB	5CB0L46881	N		●	
2	Upper Case ASM L80SMPLIMR BEL KB	5CB0L46885	N		●	
2	Upper Case ASM L80SMPLIMR ILD KB	5CB0L46877	N		●	
2	Upper Case ASM L80SMPLIMR SLV KB	5CB0L46869	N		●	
2	Upper Case ASM L80SMPLIMR SWS KB	5CB0L46891	N		●	
2	Upper Case ASM L80SMPLIMRUSINTER KB	5CB0L46888	N		●	
2	Upper Case ASM L80SMPLIMR CZE_SLK KB	5CB0L46878	N		●	

Table 4. Parts list—Overall (continued)

No.	FRU	FRU no.	CRU ID	ideapad 310-14ISK	ideapad 310-15ISK/ideapad 310-15ABR	ideapad 310-15ISK Touch
2	Upper Case ASM L80SMPLIMR BUL KB	5CB0L46870	N		●	
2	Upper Case ASM L80SMPLIMR IND KB	5CB0L46889	N		●	
2	Upper Case ASM L80SMPLIMR FRA/ARA KB	5CB0L46868	N		●	
2	Upper Case ASM L80SMBKIMR US KB	5CB0L35842	N			●
2	Upper Case ASM L80SMBKIMR CFEN KB	5CB0L35920	N			●
3	MB L80SLI76500UN16V_V2 GD4GWINRTC	5B20L35707	N	●		
3	MB L80SLI76500UN16V_V2 GD4GNOKRTC	5B20L35802	N	●		
3	MB L80SLI56200UN16V_V2 GD4GWINRTC	5B20L35782	N	●		
3	MB L80SLI56200UN16V_V2 GD4GNOKRTC	5B20L35713	N	●		
3	MB L80SLI36100UN16V_V2 GD4GWINRTC	5B20L35729	N	●		
3	MB L80SLI36100UN16V_V2 GD4GNOKRTC	5B20L35766	N	●		
3	MB L80SLI76500U UMA D4G WINRTC	5B20L35731	N	●		
3	MB L80SLI76500U UMA D4G NOKRTC	5B20L35791	N	●		
3	MB L80SLI56200U UMA D4G WINRTC	5B20L35751	N	●		
3	MB L80SLI56200U UMA D4G NOKRTC	5B20L35737	N	●		
3	MB L80SLI36100U UMA D4G WINRTC	5B20L35767	N	●		
3	MB L80SLI36100U UMA D4G NOKRTC	5B20L35809	N	●		

Lenovo ideapad 310-14ISK/ideapad 310-15ISK/ideapad 310 Touch-15ISK/ideapad 310-15ABR Hardware Maintenance Manual

Table 4. Parts list—Overall (continued)

No.	FRU	FRU no.	CRU ID	ideapad 310-14ISK	ideapad 310-15ISK/ideapad 310-15ABR	ideapad 310-15ISK Touch
3	MB L80SMI76500UN16V_V2 GD4GWINRTC	5B20L35929	N		●	
3	MB L80SMI76500UN16V_V2 GD4GNOKRTC	5B20L35914	N		●	
3	MB L80SMI56200UN16V_V2 GD4GWINRTC	5B20L35873	N		●	
3	MB L80SMI56200UN16V_V2 GD4GNOKRTC	5B20L35898	N		●	
3	MB L80SMI36100UN16V_V2 GD4GWINRTC	5B20L35890	N		●	
3	MB L80SMI36100UN16V_V2 GD4GNOKRTC	5B20L35888	N		●	
3	MB L80SMI76500U UMA D4G WINRTC	5B20L35847	N		●	
3	MB L80SMI76500U UMA D4G NOKRTC	5B20L35901	N		●	
3	MB L80SMI56200U UMA D4G WINRTC	5B20L35897	N		●	
3	MB L80SMI56200U UMA D4G NOKRTC	5B20L35927	N		●	
3	MB L80SMI36100U UMA D4G WINRTC	5B20L35833	N		●	
3	MB L80SMI36100U UMA D4G NOKRTC	5B20L35917	N		●	
3	MB L80SNI56200U UMA D4G WINRTC	5B20L35937	N			●
3	MB L80SNI56200U UMA D4G NOKRTC	5B20L35940	N			●
3	MB L80SNI36100U UMA D4G WINRTC	5B20L35939	N			●
3	MB L80SNI36100U UMA D4G NOKRTC	5B20L35942	N			●
4	FAN DC 5V L80SL	5F10L35775	N	●	●	●
5	HEATSINK DIS L80SL	5H40L35745	N	●	●	

Note: For ideapad 310-15 ISK/ideapad 310 Touch-15 ISK/ideapad 310-15ABR, the HDD CRU ID is *.

Table 4. Parts list—Overall (continued)

No.	FRU	FRU no.	CRU ID	ideapad 310-14ISK	ideapad 310-15ISK/ideapad 310-15ABR	ideapad 310-15ISK Touch
5	HEATSINK UMA L80SL	5H40L35743	N	●	●	●
6	DDR4 Memroy, DDR4 Slot Memory 2G, M471A5644EB0-CPB	5M30K59788	*		●	●
6	DDR4 Memroy, DDR4 Slot Memory 2G, HMA425S6AFR6N-TFN0	5M30K59787	*		●	●
6	DDR4 Memroy, DDR4 Slot Memory 4G, M471A5143EB0-CPB	5M30K59778	*	●	●	●
6	DDR4 Memroy, DDR4 Slot Memory 4G, MTA8ATF51264HZ-2G1A2	5M30K59777	*	●	●	●
6	DDR4 Memroy, DDR4 Slot Memory 4G, HMA451S6AFR8N-TFN0	5M30H35732	*	●	●	●
6	DDR4 Memroy, DDR4 Slot Memory 4G, RMSA3230KE68H9F-2133	5M30K62038	*	●	●	●
7	HDD (7mm & 9.5mm), 2TB 5400RPM(9.5mm), ST2000LM003 9.5mm 5400rpm 2T HDD	5H20K10149	*		●	
7	SSD, 128G, Samsung MZYL128HCHP 2.5" 5mm 128GB SSD	5SD0H45117	*		●	
7	SSD, 128G, Hynix HFS128G3BMND-3210A	5SD0K44056	*		●	
7	HDD (7mm & 9.5mm), 500G 5400RPM(7mm), ST500LT012 6G 7mm 5.4K 500G HDD	16200383	N	●	●	●
7	HDD (7mm & 9.5mm), 500G 5400RPM(7mm), HTS545050A7E660 6G 7mm 5.4K 500G HDD	5H20H14223	N	●	●	●

Note: For ideapad 310-15 ISK/ideapad 310 Touch-15 ISK/ideapad 310-15ABR, the HDD CRU ID is *.

Lenovo ideapad 310-14ISK/ideapad 310-15ISK/ideapad 310 Touch-15ISK/ideapad 310-15ABR Hardware Maintenance Manual

Table 4. Parts list—Overall (continued)

No.	FRU	FRU no.	CRU ID	ideapad 310-14ISK	ideapad 310-15ISK/ideapad 310-15ABR	ideapad 310-15ISK Touch
7	HDD (7mm & 9.5mm), 500G 5400RPM(7mm), MQ01ABF050 6G 7mm 5.4K 500G HDD	16200433	N	●	●	●
7	HDD (7mm & 9.5mm), 500G 5400RPM(7mm), WD5000LPCX-24VHAT0 7mm 5400rpm 500G HDD	5H20J35762	N	●	●	●
7	HDD (7mm & 9.5mm), 1TB 5400RPM(9.5mm), ST1000LM024 6G 9.5mm 5.4K 1T HDD	16200385	N	●	●	●
7	HDD (7mm & 9.5mm), 1TB 5400RPM(9.5mm), WD10JPCX-24UE4T0 6G 9.5mm 5.4K 1T HDD	16200393	N	●	●	●
7	HDD (7mm & 9.5mm), 1TB 5400RPM(9.5mm), TSB MQ01ABD100 6G 9.5mm 5.4K 1T HDD	16200429	N	●	●	●
7	HDD (7mm & 9.5mm), 1TB 5400RPM(9.5mm), HTS541010A9E660 6G 9.5mm 5.4K 1T HDD	16200400	N	●	●	●
7	SSHD, 500G+8G (7mm), ST500LM000 6G 7mm 500G+8G SSHD	5H20H24608	N	●		●
7	SSHD, 500G+8G (7mm), Toshiba MQ02ABF050H 7mm 5.4k 500GB+8GB SSHD	5H20H12631	N	●		●
8	WLAN, Wifi 1X1 AC+ BT 4.0, Intel 3165 1x1AC+BT PCIE M.2 WLAN	SW10H24486	*	●	●	●
8	WLAN, Wifi 1X1 AC+ BT 4.0, Cbt RTL8821AE 1x1AC+BT4.0 PCIE M.2 WLAN	SW10A11648	*	●	●	●
8	WLAN, Wifi 1X1 AC+ BT 4.0, Ltn NFA435 1x1AC+BT4.0 PCIE M.2 WLAN	SW10A11641	*	●	●	●

Table 4. Parts list—Overall (continued)

No.	FRU	FRU no.	CRU ID	ideapad 310-14ISK	ideapad 310-15ISK/ideapad 310-15ABR	ideapad 310-15ISK Touch
9	USB BOARD W/FFC L80SL	5C50L35765	N	●	●	●
10	ODD BOARD W/FFC L80SM	5C50L35865	N		●	●
11	Battery, 2cell Polymer 30W, G14 LG L15L2PB2 7.6V30Wh2cell bty	5B10K90803	N	●		
11	Battery, 2cell Polymer 30W, G14 SP/A L15M2PB2 7.5V30Wh2cell bty	5B10K87714	N	●		
11	Battery, 2cell Polymer 30W, G14 CP/C L15C2PB27.6V30Wh2cell bty	5B10K90785	N	●		
11	Battery, 2cell Polymer 30W, G14 SP/A L15M2PB2 7.4V30Wh2cell bty	5B10K87712	N	●		
11	Battery, 2cell Polymer 30W, G14 CP/C L15C2PB27.4V30Wh2cell bty	5B10K90784	N	●		
11	Battery, 2cell Polymer 39W, G14 LG L15L2PB3 7.72V39Wh2cell bty	5B10K90806	N	●		
11	Battery, 2cell Polymer 39W, G14 CP/C L15C2PB67.7V39Wh2cell bty	5B10L13961	N	●		
11	Battery, 2cell Polymer 39W, G14 SP/A L15M2PB4 7.68V39Wh2cell bty	5B10K87713	N	●		
11	Battery, 2cell Polymer 30W, G15 LG L15L2PB4 7.6V30Wh2cell bty	5B10K90804	N		●	●
11	Battery, 2cell Polymer 30W, G15 SP/A L15M2PB3 7.5V30Wh2cell bty	5B10K87722	N		●	●

Lenovo ideapad 310-14ISK/ideapad 310-15ISK/ideapad 310 Touch-15ISK/ideapad 310-15ABR Hardware Maintenance Manual

Table 4. Parts list—Overall (continued)

No.	FRU	FRU no.	CRU ID	ideapad 310-14ISK	ideapad 310-15ISK/ideapad 310-15ABR	ideapad 310-15ISK Touch
11	Battery, 2cell Polymer 30W, G15 CP/C L15C2PB37.6V30Wh2cell bty	5B10K90787	N		●	●
11	Battery, 2cell Polymer 30W, G15 SY L15S2TB0 7.3V30Wh2cell bty	5B10K88299	N		●	●
11	Battery, 2cell Polymer 30W, G15 SP/A L15M2PB3 7.4V30Wh2cell bty	5B10K87721	N		●	●
11	Battery, 2cell Polymer 30W, G15CP/C L15C2PB37.4V30Wh2cell bty	5B10K90786	N		●	●
11	Battery, 2cell Polymer 39W, G15 SP/A L15M2PB5 7.68V39Wh2cell bty	5B10K87720	N		●	●
11	Battery, 2cell Polymer 39W, G15 CP/C L15C2PB77.7V39Wh2cell bty	5B10L13960	N		●	●
11	Battery, 2cell Polymer 39W, G15 LG L15L2PB5 7.72V39Wh2cell bty	5B10K90805	N		●	●
12	DUMMY ODD L80SL BLACK	5M20L35727	*	●	●	●
12	DUMMY ODD L80SM BAY BLACK	5M20L35859	*		●	●
12	ODD, 9.0mm Rambo ODD, HLDS GUE0N 9.0mm Slim Tray Rambo ODD	5DX0J46488	*	●	●	●
12	ODD, 9.0mm Rambo ODD, PLDS DA-8AESH 9.0 mm Slim Tray Rambo ODD	5DX0L08424	*	●	●	●
12	ODD, 9.0mm Rambo ODD, TSST SU-228HB 9.0mm Slim Tray Rambo ODD	5DX0L08425	*	●	●	●

Lenovo ideapad 310-14ISK/ideapad 310-15ISK/ideapad 310 Touch-15ISK/

Table 4. Parts list—Overall (continued)

No.	FRU	FRU no.	CRU ID	ideapad 310-14ISK	ideapad 310-15ISK/ideapad 310-15ABR	ideapad 310-15ISK Touch
13	Lower Case ASM L80SMBK TEX W/SPE/ FFC	5CB0L35822	N		●	●
14	HDD BOARD FOR 2ND HDD	5C50L67280	N		●	

LCD FRUs

In Lenovo ideapad 310-14ISK/ideapad 310-15ISK/ideapad 310 Touch-15ISK/ideapad 310-15ABR, there are following types of LCDs.

- "14.0 -in. HD TFT"
- "15.6 -in. HD TFT"
- "15.6 Touch-in. HD TFT"

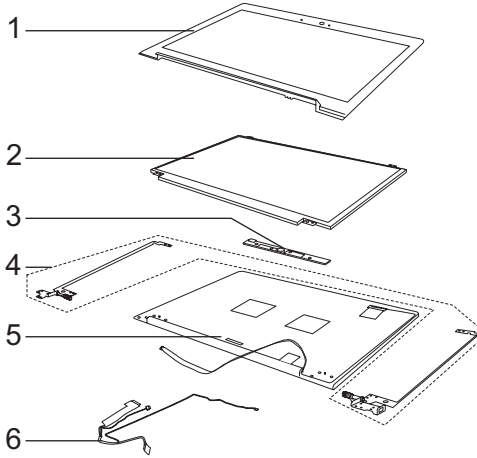

14.0-in. HD TFT

Table 5. Parts list—14.0-in. HD TFT

No.	FRU	FRU no.	CRU ID
1	LCD BEZELL80SL BK TEX W/CAMMYLAR	5B30L35741	N
1	LCD BEZELL80SL BK IMR W/CAMMYLAR	5B30L35725	N
2	Panel, 14.0" HD TN Slim GL (3.0mm), AUO B140XTN02.D 2A HD G S NB	5D10H13021	N
2	Panel, 14.0" HD TN Slim GL (3.0mm), IN N140BGA-EB3 HDT G S NB	5D10K85754	N
2	Panel, 14.0" HD TN Slim GL (3.0mm), BO NT140WHM-N31 HDT G S NB	5D10K81083	N
2	Panel, 14.0" HD TN Slim GL (3.0mm), LG LP140WHU-TPG1 HDT G S NB	5D10K81460	N
2	Panel, 14.0" HD TN Slim GL (3.0mm), IV M140NWR6-R0 HDT G S NB	5D10K81642	N
2	Panel, 14.0" HD TN Slim GL (3.0mm), SD LTN140AT39-L01 HDT G S NB	5D10K81457	N
2	Panel, 14.0 FHD TN Slim GL (3.0mm), AU B140HTN01.F 0A FHDT G S NB	5D10L08703	N
2	Panel, 14.0 FHD TN Slim GL (3.0mm), IN N140HGE-EBA C4 FHDT G S NB	5D10K93438	N
2	Panel, 14.0 FHD TN Slim GL (3.0mm), BO HB140FH1-301 V4.1 FHDT G S NB	5D10H56753	N
3	CAMERA L80SL HD W/1MIC	5C20L35738	N
3	CAMERA L80SL 0.3M W/1MIC	5C20L35699	N
3	Camera, HD W /Single MIC, BIS BNCF1NKTK HD NB camera	SC20K75690	N
3	Camera, HD W /Single MIC, CCY CNFFH42 HD NB camera	SC20K75697	N
3	Camera, HD W /Single MIC, LTN 5SF128N2 HD NB camera	SC20K76291	N
3	Camera, HD W /Single MIC, AVC HAA-8F4A02 HD NB camera	SC20K75696	N
3	Camera, 0.3M W/ Single MIC, BIS BNCGVTKTL 0.3M NB camera	SC20K75693	N
3	Camera, 0.3M W/ Single MIC, CCY CNFF024 0.3M NB camera	SC20K75687	N
3	Camera, 0.3M W/ Single MIC, LTN 5SF009N2 0.3M NB camera	SC20K76289	N
3	Camera, 0.3M W/ Single MIC, AVC HAA-584B03 0.3M NB camera	SC20K84861	N
4	HINGE L+R L80SL	5H50L35704	N
5	LCD Cover L80SL SR IMR W/ ANTE EDP	5CB0L35803	N
5	LCD Cover L80SL RED IMR W/ ANTE EDP	5CB0L35734	N
5	LCD Cover L80SL BK TEX W/ ANTE EDP	5CB0L35804	N
6	EDP CABLE L80SL	5C10L35718	N

15.6-in. HD TFT

Table 6. Parts list—15.6-in. HD TFT

No.	FRU	FRU no.	CRU ID
1	LCD BEZEL L80SM BK TEX W/CAMMYLAR	5B30L35831	N
1	LCD BEZEL L80SM BK IMR W/CAMMYLAR	5B30L35928	N
2	Panel, 15.6" HD TN Slim GL (3.2mm), AU B156XTN07.0 1A HDT G S NB	5D10K90419	N
2	Panel, 15.6" HD TN Slim GL (3.2mm), INX N156BGA- EB2 HDT G S NB	5D10K81084	N
2	Panel, 15.6" HD TN Slim GL (3.2mm), BO NT156WHM-N32 V8 HDT G S NB	5D10K81087	N
2	Panel, 15.6" HD TN Slim GL (3.2mm), SD LTN156AT38-L02 HDT G S NB	5D10K81459	N
2	Panel, 15.6" HD TN Slim GL (3.2mm), LG LP156WHU- TPG1 HDT G S NB	5D10K81458	N
2	Panel, 15.6" FHD TN Slim GL (3.2mm), AU B156HTN03.9 0B FHDT G S NB	5D10K81095	N
2	Panel, 15.6" FHD TN Slim GL (3.2mm), IN N156HGA- EBB FHDT G S NB	5D10K93436	N
2	Panel, 15.6" FHD TN Slim GL (3.2mm), BO NT156FHM- N31 FHDT G S NB	5D10K93437	N
3	CAMERA L80SL HD W/1MIC	5C20L35738	N
3	CAMERA L80SL 0.3M W/1MIC	5C20L35699	N
3	Camera, HD W /Single MIC, BIS BNCF1NKTK HD NB camera	SC20K75690	N
3	Camera, HD W /Single MIC, CCY CNFFH42 HD NB camera	SC20K75697	N
3	Camera, HD W /Single MIC, LTN 5SF128N2 HD NB camera	SC20K76291	N
3	Camera, HD W /Single MIC, AVC HAA-8F4A02 HD NB camera	SC20K75696	N
3	Camera, 0.3M W/ Single MIC, BIS BNCGVTKTL 0.3M NB camera	SC20K75693	N
3	Camera, 0.3M W/ Single MIC, CCY CNFF024 0.3M NB camera	SC20K75687	N
3	Camera, 0.3M W/ Single MIC, LTN 5SF009N2 0.3M NB camera	SC20K76289	N
3	Camera, 0.3M W/ Single MIC, AVC HAA-584B03 0.3M NB camera	SC20K84861	N
4	HINGE L+R L80SM	5H50L35870	N
5	LCD Cover L80SM BK TEX W/ ANTE EDP	5CB0L35815	N
5	LCD Cover L80SM BK IMR W/ ANTE EDP	5CB0L35899	N
5	LCD Cover L80SM RED IMR W/ ANTE EDP	5CB0L35860	N
5	LCD Cover L80SM SR IMR W/ ANTE EDP	5CB0L35856	N
5	LCD Cover L80SM PL IMR W/ ANTE EDP	5CB0L46876	N
5	EDP CABLE L80SM	5C10L35864	N

15.6 Touch-in. HD TFT

Table 7. Parts list—15.6 Touch-in. HD TFT

No.	FRU	FRU no.	CRU ID
1	LCD BEZEL L80SM BK TEX W/CAMMYLAR	5B30L35831	N
2	On cell Touch LCD, 15.6' On-cell HD TN GL Slim Touch LCD, AU B156XTK01.0 HDT G S NB(T)	5D10K81094	N
2	On cell Touch LCD, 15.6' On-cell HD TN GL Slim Touch LCD, IN N156BGN-E41 HDT G S NB(T)	5D10K81098	N
3	Camera, HD W /Single MIC, BIS BNCF1NKTK HD NB camera	SC20K75690	N
3	Camera, HD W /Single MIC, CCY CNFFH42 HD NB camera	SC20K75697	N
3	Camera, HD W /Single MIC, LTN 5SF128N2 HD NB camera	SC20K76291	N
3	Camera, HD W /Single MIC, AVC HAA-8F4A02 HD NB camera	SC20K75696	N
3	CAMERA L80SL HD W /1MIC	5C20L35738	N
5	LCD COVER ASSY 15TS BLACK-TEX	5CB0L35938	N
6	EDP CABLE L80SN	5C10L35941	N

Miscellaneous parts

Table 8. Parts list—Miscellaneous parts

FRU	P/N	CRU ID	ideapad 310-14ISK	ideapad 310-15ISK/ideapad 310-15ABR	ideapad 310 Touch - 15ISK
System miscellaneous parts:					
• (a) ODD BRACKET L80SL	5B40L35764	N	●	●	●
• (b) ODD BEZEL L80SL BLACK	5B30L35799	N	●	●	●
• (c) HDD BRACKET L80SL 7MM W/SPONGE	5B40L35742	N	●		
• (c) HDD BRACKET L80SL 9.5MM W/SPONGE	5B40L35773	N	●		
• (c) HDD BRACKET L80SM W/SPONGE	5B40L35846	N		●	●
• (d) HDD DOOR L80SM FOR 7MM HDD	5CB0L35896	*		●	●
• (d) HDD DOOR L80SM FOR 9.5MM HDD	5CB0L35930	*		●	●
• (e) RAM Cover L80SL	5CB0L35709	*	●	●	●
Cable miscellaneous parts:					
• (f) HDD FFC L80SL CONNECT HDD AND MB	5C10L35800	N	●		
• (f) HDD FFC L80SM CONNECT HDD AND MB	5C10L35858	N		●	●
Note: Italicized letters in parentheses are references to the exploded view in “Overall” on page 73.					

Screws

Table 9. Parts list—Screws

FRU	P/N	CRU ID	ideapad 310-14ISK	ideapad 310-15ISK/ideapad 310-15ABR	ideapad 310 Touch-15ISK
ACLU1 Screw D-C/D-KB/ODD-D-MB-KB/FAN	90205118	N	●	●	●
Screw L Y700-15ACZ Hinge 3	5S10K26863	N	●	●	●
AILZA Screw MM2D7.4+4.6LK3.5D1T	90203992	N	●	●	●
AILZA Screw M M 3.0D 3.0L K 4.9D	90203986	N	●	●	●
ACLU1 Screw Panel-A/MB-D/IO BD-D	90205117	N	●	●	●
Screw L300-IBR 2.5D3.5LK5.3D0.5T	5S10K14049	N	●		
QIQY5 SCREW 2D3LK4.5DZKNL+CR3+0.4T	90001118	N	●	●	●
ACLU1 Screw Hinge-D	90205119	N		●	●

AC adapters

Table 10. Parts list—3-pin AC adapters

FRU	P/N	CRU ID	ideapad 310-14ISK	ideapad 310-15ISK/ideapad 310-15ABR	ideapad 310 Touch-15ISK
Adapter, 45W wall mount with round plug (Low cost 45w Adapter), Delta ADP-45DW AA 20V2.25A adapter	5A10H43620	*	●	●	
Adapter, 45W wall mount with round plug (Low cost 45w Adapter), Delta ADP-45DW JA 20V2.25A adapter	5A10H43623	*	●	●	
Adapter, 45W wall mount with round plug (Low cost 45w Adapter), Delta ADP-45DW BA 20V2.25A adapter	5A10H43630	*	●	●	●
Adapter, 45W wall mount with round plug (Low cost 45w Adapter), Delta ADP-45DW DA 20V2.25A adapter	5A10H43621	*	●	●	
Adapter, 45W wall mount with round plug (Low cost 45w Adapter), Delta ADP-45DW HA 20V2.25A adapter	5A10H43627	*	●	●	
Adapter, 45W wall mount with round plug (Low cost 45w Adapter), Delta ADP-45DW GA 20V2.25A adapter	5A10H43617	*	●	●	
Adapter, 45W wall mount with round plug (Low cost 45w Adapter), Delta ADP-45DW EA 20V2.25A adapter	5A10H43626	*	●	●	
Adapter, 45W wall mount with round plug (Low cost 45w Adapter), Delta ADP-45DW CA 20V2.25A adapter	5A10H43632	*	●	●	
Adapter, 45W wall mount with round plug (Low cost 45w Adapter), Delta ADP-45DW KA 20V2.25A adapter	5A10H43624	*	●	●	
Adapter, 45W wall mount with round plug (Low cost 45w Adapter), Liteon PA-1450-55LN 20V2.25A adapter	5A10H42921	*	●	●	

Table 10. Parts list—3-pin AC adapters (continued)

FRU	P/N	CRU ID	ideapad 310-14ISK	ideapad 310-15ISK/ideapad 310-15ABR	ideapad 310 Touch-15ISK
Adapter, 45W wall mount with round plug (Low cost 45w Adapter), Liteon PA-1450-55LG 20V2.25A adapter	5A10H42920	*	●	●	
Adapter, 45W wall mount with round plug (Low cost 45w Adapter), Liteon PA-1450-55LL 20V2.25A adapter	5A10H42923	*	●	●	●
Adapter, 45W wall mount with round plug (Low cost 45w Adapter), Liteon PA-1450-55LK 20V2.25A adapter	5A10H42917	*	●	●	
Adapter, 45W wall mount with round plug (Low cost 45w Adapter), Liteon PA-1450-55LI 20V2.25A adapter	5A10H42926	*	●	●	
Adapter, 45W wall mount with round plug (Low cost 45w Adapter), Liteon PA-1450-55LR 20V2.25A adapter	5A10H42919	*	●	●	
Adapter, 45W wall mount with round plug (Low cost 45w Adapter), Liteon PA-1450-55LS 20V2.25A adapter	5A10H42922	*	●	●	
Adapter, 45W wall mount with round plug (Low cost 45w Adapter), Liteon PA-1450-55LU 20V2.25A adapter	5A10H42925	*	●	●	
Adapter, 45W wall mount with round plug (Low cost 45w Adapter), Liteon PA-1450-55LZ 20V2.25A adapter	5A10H42918	*	●	●	
Adapter, 45W wall mount with round plug (Low cost 45w Adapter), Chicony ADL45WCA 20V2.25A adapter	5A10H43629	*	●	●	
Adapter, 45W wall mount with round plug (Low cost 45w Adapter), Chicony ADL45WCB 20V2.25A adapter	5A10H43618	*	●	●	

Lenovo ideapad 310-14ISK/ideapad 310-15ISK/ideapad 310 Touch-15ISK/ideapad 310-15ABR Hardware Maintenance Manual

Table 10. Parts list—3-pin AC adapters (continued)

FRU	P/N	CRU ID	ideapad 310-14ISK	ideapad 310-15ISK/ideapad 310-15ABR	ideapad 310 Touch-15ISK
Adapter, 45W wall mount with round plug (Low cost 45w Adapter), Chicony ADL45WCC 20V2.25A adapter	5A10H43625	*	●	●	●
Adapter, 45W wall mount with round plug (Low cost 45w Adapter), Chicony ADL45WCD 20V2.25A adapter	5A10H43631	*	●	●	
Adapter, 45W wall mount with round plug (Low cost 45w Adapter), Chicony ADL45WCK 20V2.25A adapter	5A10H43619	*	●	●	
Adapter, 45W wall mount with round plug (Low cost 45w Adapter), Chicony ADL45WCE 20V2.25A adapter	5A10H43633	*	●	●	
Adapter, 45W wall mount with round plug (Low cost 45w Adapter), Chicony ADL45WCF 20V2.25A adapter	5A10H43622	*	●	●	
Adapter, 45W wall mount with round plug (Low cost 45w Adapter), Chicony ADL45WCG 20V2.25A adapter	5A10H43628	*	●	●	
Adapter, 45W wall mount with round plug (Low cost 45w Adapter), Chicony ADL45WCH 20V2.25A adapter	5A10H43616	*	●	●	
Adapter, 65W wall mount with round plug (Low cost 65W Adapter), Delta ADLX65CDGC2A 20V3.25A adapter	5A10K78762	*	●	●	

Table 10. Parts list—3-pin AC adapters (continued)

FRU	P/N	CRU ID	ideapad 310-14ISK	ideapad 310-15ISK/ideapad 310-15ABR	ideapad 310 Touch-15ISK
Adapter, 65W wall mount with round plug (Low cost 65W Adapter), Delta ADLX65CDGG2A 20V3.25A adapter	5A10K78739	*	●	●	
Adapter, 65W wall mount with round plug (Low cost 65W Adapter), Delta ADLX65CDGU2A 20V3.25A adapter	5A10K78742	*	●	●	
Adapter, 65W wall mount with round plug (Low cost 65W Adapter), Delta ADLX65CDGK2A 20V3.25A adapter	5A10K78743	*	●	●	
Adapter, 65W wall mount with round plug (Low cost 65W Adapter), Delta ADLX65CDGI2A 20V3.25A adapter	5A10K78759	*	●	●	
Adapter, 65W wall mount with round plug (Low cost 65W Adapter), Delta ADLX65CDGR2A 20V3.25A adapter	5A10K78748	*	●	●	
Adapter, 65W wall mount with round plug (Low cost 65W Adapter), Delta ADLX65CDGA2A 20V3.25A adapter	5A10K78741	*	●	●	
Adapter, 65W wall mount with round plug (Low cost 65W Adapter), Delta ADLX65CDGE2A 20V3.25A adapter	5A10K78753	*	●	●	
Adapter, 65W wall mount with round plug (Low cost 65W Adapter), Delta ADLX65CDGB2A 20V3.25A adapter	5A10K78754	*	●	●	

// Lenovo ideapad 310-14ISK/ideapad 310-15ISK/ideapad 310 Touch-15ISK/ideapad 310-15ABR Hardware Maintenance Manual

Table 10. Parts list—3-pin AC adapters (continued)

FRU	P/N	CRU ID	ideapad 310-14ISK	ideapad 310-15ISK/ideapad 310-15ABR	ideapad 310 Touch-15ISK
Adapter, 65W wall mount with round plug (Low cost 65W Adapter), Liteon ADLX65CLGC2A 20V3.25A adapter	5A10K78736	*	●	●	
Adapter, 65W wall mount with round plug (Low cost 65W Adapter), Liteon ADLX65CLGG2A 20V3.25A adapter	5A10K78749	*	●	●	
Adapter, 65W wall mount with round plug (Low cost 65W Adapter), Liteon ADLX65CLGU2A 20V3.25A adapter	5A10K78745	*	●	●	
Adapter, 65W wall mount with round plug (Low cost 65W Adapter), Liteon ADLX65CLGK2A 20V3.25A adapter	5A10K78750	*	●	●	
Adapter, 65W wall mount with round plug (Low cost 65W Adapter), Liteon ADLX65CLGI2A 20V3.25A adapter	5A10K78740	*	●	●	
Adapter, 65W wall mount with round plug (Low cost 65W Adapter), Liteon ADLX65CLGR2A 20V3.25A adapter	5A10K78746	*	●	●	
Adapter, 65W wall mount with round plug (Low cost 65W Adapter), Liteon ADLX65CLGA2A 20V3.25A adapter	5A10K78758	*	●	●	
Adapter, 65W wall mount with round plug (Low cost 65W Adapter), Liteon ADLX65CLGE2A 20V3.25A adapter	5A10K78752	*	●	●	

Table 10. Parts list—3-pin AC adapters (continued)

FRU	P/N	CRU ID	ideapad 310-14ISK	ideapad 310-15ISK/ideapad 310-15ABR	ideapad 310 Touch-15ISK
Adapter, 65W wall mount with round plug (Low cost 65W Adapter), Liteon ADLX65CLGB2A 20V3.25A adapter	5A10K78755	*	●	●	
Adapter, 65W wall mount with round plug (Low cost 65W Adapter), Chicony ADLX65CCGC2A 20V3.25A adapter	5A10K78744	*	●	●	
Adapter, 65W wall mount with round plug (Low cost 65W Adapter), Chicony ADLX65CCGG2A 20V3.25A adapter	5A10K78756	*	●	●	
Adapter, 65W wall mount with round plug (Low cost 65W Adapter), Chicony ADLX65CCGU2A 20V3.25A adapter	5A10K78761	*	●	●	
Adapter, 65W wall mount with round plug (Low cost 65W Adapter), Chicony ADLX65CCGK2A 20V3.25A adapter	5A10K78757	*	●	●	
Adapter, 65W wall mount with round plug (Low cost 65W Adapter), Chicony ADLX65CCGI2A 20V3.25A adapter	5A10K78760	*	●	●	
Adapter, 65W wall mount with round plug (Low cost 65W Adapter), Chicony ADLX65CCGR2A 20V3.25A adapter	5A10K78747	*	●	●	
Adapter, 65W wall mount with round plug (Low cost 65W Adapter), Chicony ADLX65CCGA2A 20V3.25A adapter	5A10K78737	*	●	●	

Table 10. Parts list—3-pin AC adapters (continued)

FRU	P/N	CRU ID	ideapad 310-14ISK	ideapad 310-15ISK/ideapad 310-15ABR	ideapad 310 Touch-15ISK
Adapter, 65W wall mount with round plug (Low cost 65W Adapter), Chicony ADLX65CCGE2A 20V3.25A adapter	5A10K78751	*	●	●	
Adapter, 65W wall mount with round plug (Low cost 65W Adapter), Chicony ADLX65CCGB2A 20V3.25A adapter	5A10K78738	*	●	●	

Notices

Lenovo may not offer the products, services, or features discussed in this document in all countries. Consult your local Lenovo representative for information on the products and services currently available in your area. Any reference to a Lenovo product, program, or service is not intended to state or imply that only that Lenovo product, program, or service may be used. Any functionally equivalent product, program, or service that does not infringe any Lenovo intellectual property right may be used instead. However, it is the user's responsibility to evaluate and verify the operation of any other product, program, or service.

Lenovo may have patents or pending patent applications covering subject matter described in this document. The furnishing of this document does not give you any license to these patents.

LENOVO GROUP LTD. PROVIDES THIS PUBLICATION "AS IS" WITHOUT WARRANTY OF ANY KIND, EITHER EXPRESS OR IMPLIED, INCLUDING, BUT NOT LIMITED TO, THE IMPLIED WARRANTIES OF NON-INFRINGEMENT, MERCHANTABILITY OR FITNESS FOR A PARTICULAR PURPOSE. Some jurisdictions do not allow disclaimer of express or implied warranties in certain transactions, therefore, this statement may not apply to you.

This information could include technical inaccuracies or typographical errors. Changes are periodically made to the information herein; these changes will be incorporated in new editions of the publication. Lenovo may make improvements and/or changes in the product(s) and/or the program(s) described in this publication at any time without notice.

The products described in this document are not intended for use in implantation or other life support applications where malfunction may result in injury or death to persons. The information contained in this document does not affect or change Lenovo product specifications or warranties. Nothing in this document shall operate as an express or implied license or indemnity under the intellectual property rights of Lenovo or third parties. All information contained in this document was obtained in specific environments and is presented as an illustration. The result obtained in other operating environments may vary.

Lenovo may use or distribute any of the information you supply in any way it believes appropriate without incurring any obligation to you.

Any references in this publication to non-Lenovo Web sites are provided for convenience only and do not in any manner serve as an endorsement of those Web sites. The materials at those Web sites are not part of the materials for this Lenovo product, and use of those Web sites is at your own risk.

Any performance data contained herein was determined in a controlled environment. Therefore, the result obtained in other operating environments may vary significantly. Some measurements may have been made on development-level systems and there is no guarantee that these measurements will be the same on generally available systems. Furthermore, some measurements may have been estimated through extrapolation. Actual results may vary. Users of this document should verify the applicable data for their specific environment.

Trademarks

The following terms are trademarks or registered trademarks of Lenovo in the United States, other countries, or both.

Lenovo
OneKey

Microsoft and Windows are trademarks of Microsoft Corporation in the United States, other countries, or both.

Other company, products, or service names may be trademarks or service marks of others.